

LINIUS CONTINUOUS LOUVRE SYSTEM



OUR MISSION

Creating healthy spaces



Paul Renson

"Renson® specialises in ventilation, sun protection and outdoor. With experience dating back to 1909, and an integrated team of over 1000 employees, we develop systems and solutions which provide consumers with a healthy and comfortable living and working environment, also taking into account energy efficiency and the use of renewable energy. We develop innovative products and systems, and offer total solutions to make every house into a healthy and comfortable home.

"We also appreciate the aesthetic values of every building, allowing our sun control and ventilation systems to be incorporated invisibly into your home. Our patio covers and aluminium blades for covering façades provide clear accents, offering added value to the architecture. Inside, we ensure that doors are integrated invisibly with no conspicuous frames or visible joints."

Discover how Renson® products can optimise the comfort experience while guaranteeing a contemporary design.

"We develop innovative products and systems allowing for aesthetic integration in every building."



TABLE OF CONTENTS

INTRODUCTION		SUPPORTING STRUCTURES LINIUS®	88
Purpose of the continuous louvre system [CLS]	5	SYSTEM DEPTH	92
Selection criteria	6	FIXING ELEMENTS	94
Water penetration tests	8		
OVERVIEW	10	ACCESSORIES	
PRODUCTS		Mesh	100
BLADE TYPES	13	Sills	103
L.033.01	18	Aluminium frames	104
L.033HF	22	Doors	106
L.033CL/L.033IM1	24		
L.033V/L.033.08	26	SPECIALTIES	
L.050.00	28	Linius® unitized system	110
L.050HF / L.050.25	32	Curved blades	111
L.050CL / L.050IM1 / L.050IM2	34	Stand alone support structures	112
L.050W / L.050WV / L.050WS	36	Acoustic applications	113
L.060	38	Mitred corners	114
L.060HF	40	Special shapes	115
L.060AC	42	Block blades L.033 and L.050	116
L.065	44	Turrets	117
L.065AL	46	Louvre grilles	119
L.066	48	Aesthetic façade cladding with	
L.066.01 / L.066.06 / L.066S	50	Sunclips® and Icarus® blades	121
L.066CL / L.066IM1	52		
L.066V	54	STORAGE AND MAINTENANCE	122
L.066P	56		
L.075	58		
L.075W	60		
L.075HF	62		
L.095	64		
L.095.01 / L.095S	66		
L.120	68		
L.150	72		
L.150ACS / L.150ACL	74		
L.150DAC	76		
L.170	78		
L.170ACS / L.170ACL	80		
L.170DAC	82		
Sunclips® Evo	84		

Linius® L.150ACS



PURPOSE OF THE CONTINUOUS LOUVRE SYSTEM (CLS)

The continuous louvre system consists of a support structure to which blades are fitted. The support structure carries the complete louvre assembly and is formed by vertically or horizontal placed mullions fixed by brackets at set distances. Depending on the structure, Renson® offers different mullion types. Blade supports are permanently fixed to the mullions allowing the blades to be clip-locked onto their supports. The method of construction is simple and well tested. Mitred corners, doors, vermin, bird or insect screens can all be incorporated. Depending on the application, different constructions are possible.

1. Screening

An application ideal for concealing unsightly equipment from view.

2. Ventilation

An assembly allowing the air flow in and out of a building whilst restricting the entry of rain. Here the CLS offers by far the best aesthetic solution.

3. Screening against the weather

The continuous louvres system protects your installation from wind, rain and vermin.

4. Acoustics

Fitted with acoustic blades, the CLS is ideal for the screening of noisy installations. The structure of the louvres system together with the noise damping qualities ensure that noise is strongly damped, while keeping good ventilation.

5. Aesthetic cladding

Applications in which the blade profile design is preferred to other applications.

6. Interior

Interior cladding, possibly incorporating back lighting.



01



02



03



04



05



06

SELECTION CRITERIA

This chapter offers you assistance in selecting the ideal Renson® louvre ventilation system. Some definitions well-known in the field of natural ventilation are explained.

If the CLS is only used for aesthetic reasons, the theoretical values calculated using the formulas below can still provide an added value.

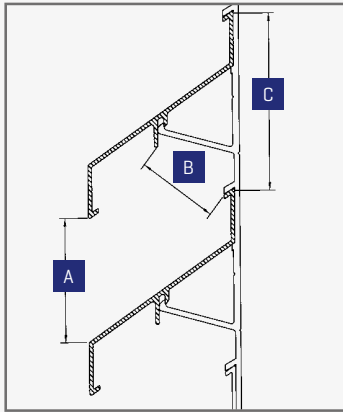

A. Visual distance between 2 blades
B. Narrowest opening between 2 blades
C. The pitch of the blade

GEOMETRIC TERMS

VISUAL FREE AREA^(*) = The visual free area is determined by the ratio between the visual distance between two blades [A] and the pitch of the blade [C].

PHYSICAL FREE AREA^(*) = The physical free area is determined by the ratio between the narrowest opening between two blades [B] and the pitch of the blade [C].

^(*) Both definitions of the free area do not take into account the influence of top and bottom blades.

AIRFLOW TERMS

K-FACTOR = The K-factor is a value describing the aerodynamic resistance to air flow. Contrary to the free area it describes the relationship between the air flow through the louvre and the pressure drop over it. For exact interpretation purposes, the calculation is explained step by step below.

To find the resistance to air flow due to the insertion of a louvre into an opening, a K-factor must be used. This factor is determined by trial and error. Where specific volumes or air speeds are required, one can better not use the free area to calculate the drop of pressure over or the size of the louvre.

Renson® recommends the use of K-factors which are established by the actual testing of a louvre. Blades with the same free area can have different K-factors. This is caused by small differences in the shape of the profiles [e.g. different blade gradient, different shape of the edges of the blades, etc.].

The free area must be used in cases where the open part of the CLS must be equal to a certain percentage of the floor surface.

C_e = Entry loss coefficient = a value describing the aerodynamic channelling of the airflow on entry. This value represents the ratio of the actual airflow to the theoretical airflow.

C_d = Discharge loss coefficient = a value describing the aerodynamic channelling of the airflow on discharge. This value represents the ratio of the actual airflow to the theoretical airflow.

Before one can determine the pressure drop one must determine the air speed using the following equation:

$$\text{Air speed} = \frac{\text{FLOW RATE}}{\text{SURFACE}} \quad \text{[a]}$$

Flow rate = m³/s the volume of air passing through the CLS
 Surface area = m² the size of the louvre (front view)
 Air speed = m/s the speed of the approaching air at the front of the CLS. (This is the result of a certain volume passing through the CLS.)

If two elements are known in this equation, one can calculate the third.

$$\text{Pressure drop} = K \times 0,6 \times \text{Air speed}^2 \quad \text{[b]}$$

One can transpose the equations to determine dimensions, air speeds or pressure drop.

Link between K-factor and c-coefficient:

$$K = \frac{1}{C^2}$$

USE OF THE K-FACTOR METHOD

METHOD 1: identify suitable louvre type for a certain opening size

1. Determine the required air flow rate
2. Determine the available opening (size of the louvre)
3. Determine the maximum permitted pressure drop
4. Choose the appropriate louvre type based on the K-Factor

EXAMPLE OF METHOD 1

Which type of louvre is suitable to achieve the desired ventilation volume of 55,000 m³/h with a maximum pressure drop of 25 Pa and an opening of 10 m²?

Calculation:

Calculation formula [a]
 Flow rate = 55000 / 3600 = 15,28 m³/s
 Size of the louvre = 10 m²

$$\text{Air speed} = 15,28 \text{ m}^3/\text{s} / 10 \text{ m}^2$$

$$[\text{surface area}] = 1,53 \text{ m/s}$$

Calculation formula [b]

Pressure drop = 25 Pa
 Air speed = 1,53 m/s

$$\text{K-Factor} = 25 / [0,6 \times 1,53^2] = 17,80$$

This is the maximum K-value to achieve the desired volume with a certain pressure drop and size. Blade types L.050, L.050HF, L.060AC, L.060HF, L.065, L.066, L.075, L.095 and L.120 can be recommended. The final choice depends on personal preference.

ACOUSTIC TERMS

dB(a) = the decibel [dB] in this brochure is used to characterize the noise reduction of a louvre. The A-weight [dB(a)] shows that the acoustic tests have been taken out according to the sensitivity of the human sound spectrum.

R_w [C;C_r] = weighted sound reduction index, used to characterise glazing, brick walls, wall louvres, etc.

METHOD 2: determine required louvre size when louvre type is already chosen

1. Choose preferred louvre type
2. Determine the air speed at the face of the louvre by means of the K-factor and the maximum pressure drop
3. Determine the required air flow rate
4. Determine the minimum louvre size

EXAMPLE OF METHOD 2

Blade type L.050.00 is preferred by the architect. What size is required to achieve a maximum pressure drop of 30 Pa for a given flow rate of 10,000 m³/h?

Calculation:

Calculation formula [b]
 K [L.050.00] = 12,57

$$\text{Air speed} = \sqrt{\frac{30}{0,6 \times 12,57}} = 1,99 \text{ m/s}$$

Calculation formula [a]

Flow rate = 10.000 / 3.600 = 2,78 m³/s

$$\text{Surface area} = \frac{2,78 \text{ m}^3/\text{s}}{1,99 \text{ m/s}} = 1,39 \text{ m}^2$$

This is the minimum surface area of louvre type L.050.00 needed to obtain a pressure drop of less than 30 Pa at a flow rate of 10,000 m³/h.

WATER PENETRATION TESTS

THE PRINCIPLE

The Renson® louvres were subjected to tests according to EN13030:2001 in Great Britain by BSRIA, a body accredited worldwide.

A wall of 1 m², possibly fitted with a stainless steel 304 mesh, was tested in torrential rain with a capacity of 75 litres/hour and a wind speed of 13 m/second. The weather performance class table is drawn up depending on the results obtained, i.e. the quantity of water passing through the louvre.

WITHOUT WATER CHANNEL

Test of a standard CLS

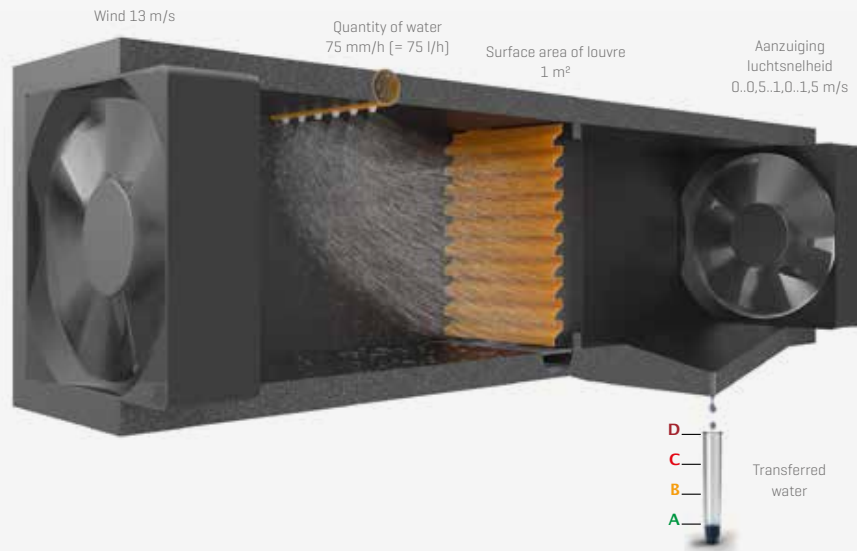

WITH WATER CHANNEL

Test of a CLS with mesh and sill

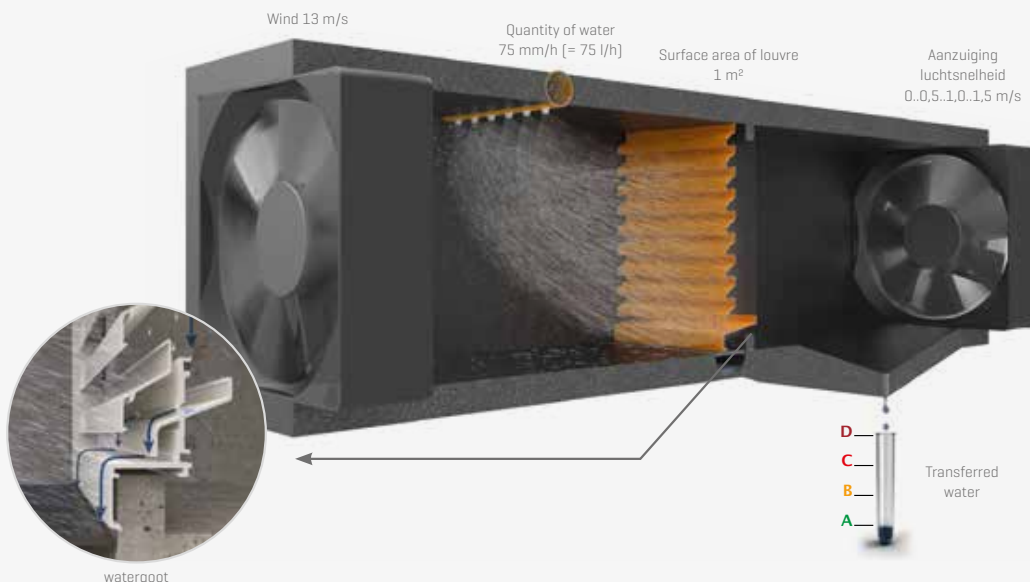

	Class	% watertightness	Suction air resistance class (C_e -coefficient)
Very good rain protection	A	100 - 99	$C_e > 0,4$: 1
Good rain protection	B	98,9 - 95	$0,3 < C_e < 0,4$: 2
Average rain protection	C	94,9 - 80	C_e : 0,2 - 0,299: 3
Low rain protection	D	< 80	$C_e < 0.199$: 4

Type	Air speed (m/s)	Standard without sill and mesh Class	With sill and mesh Class	Suction air resistance class (C_e -Coefficient)
Extreme L.050W 450	0,0	-	A	2
	1,0	-	A	
	2,0	-	A	
	3,0	-	A	
	3,5	-	C	
Extreme L.050WV 450V	0,0	-	A	2
	1,0	-	A	
	2,0	-	A	
	3,0	-	A	
	4,0	-	A	
L.075W 475/475GL	0,0	-	A	2
	0,5	-	B	
	1,0	-	B	
	1,5	-	C	
	2,0	-	D	
L.066V (Vertical standing blades) 452v	0,0	-	A	4
	0,5	-	A	
	1,0	-	A	
	1,5	-	A	
	2,0	-	C	
L.066V 452	0,0	-	A	4
	1,0	-	A	
	1,5	-	B	
	2,0	-	D	
	-	-	-	
L.033.08 491/494	0,0	-	A	4
	0,5	-	A	
	1,0	-	C	
	1,5	-	D	
	-	-	-	
L.033V 422/428	0,0	A	A	4
	0,5	B	A	
	1,0	C	B	
	1,5	C	C	
	2,0	D	D	
L.033.01 411/414/431	0,0	B	A	4
	0,5	-	A	
	1,0	C	B	
	1,5	-	D	
	-	-	-	
L.066.01 451	0,0	B	-	3
	0,5	C	-	
	1,0	C	-	
	1,5	C	-	
	2,0	D	-	
L.050.00 421/424	0,0	C	B	3
	0,5	C	C	
	1,0	D	C	
	2,0	D	C	
	2,5	D	D	
L.050IM1	0,0	C	-	3
	1,0	C	-	
	1,5	D	-	
L.050IM2	0,0	C	-	3
	0,5	C	-	
	1,0	D	-	
	1,5	D	-	
L.095.01 425/425GL	0,0	C	B	3
	0,5	C	B	
	1,0	C	C	
	1,5	D	C	
	2,0	-	D	
L.150ACS 446	0,0	-	A	3
	0,5	-	B	
	1,0	-	C	
	1,5	-	D	
	2,0	-	D	
L.066IM1	0,0	B	-	3
	0,5	B	-	
	1,0	B	-	
	1,5	D	-	
L.075HF	0,0	C	B	3
	0,5	C	B	
	1,0	C	C	
	1,5	C	C	
	2,0	D	D	

OVERVIEW TABLE

BLADE TYPE	Pitch (mm)	Blade height (mm)	Materials	Mesh	Curved	Door	Mitred corner	Friction coefficient C_{fy}	Friction coefficient C_{fz}
L.033.01	33,3	37,5	Alu	Behind	yes	yes	yes	1,34	0,44
L.033.08	33,3	42,3	Alu	Behind	no	yes	yes	1,3	0,5
L.033HF	33,3	37,5	Alu	Behind	yes	yes	yes	1,34	0,44
L.033V	33,3	37,6	Alu	Behind	no	yes	yes	1,4	-0,2
L.033CL	33,3	38,2	Alu	-	no	yes	yes	1,34	0,44
L.033IM1	33,3	38,2	Alu	Integrated	no	yes	yes	1,34	0,44
L.050.00	50	56	Alu	Behind	yes	yes	yes	1,28	0,74
L.050.25	50	60	Alu	Behind	no	yes	yes	1,34	0,44
L.050HF	50	50	Alu	Behind	yes	yes	yes	1,21	0,85
L.050CL	50	60	Alu	-	no	yes	yes	1,3	0,74
L.050W	50	89,6	Alu	Behind	no	no	yes	1,3	0,95
L.050WV	50	89,6	Alu	Behind	no	no	yes	1,3	0,95
L.050WS	50	50,5	Alu	Behind	no	yes	yes	1,28	0,74
L.050IM1	50	60	Alu	Integrated	no	yes	yes	1,3	0,74
L.050IM2	50	60	Alu	Integrated	no	yes	yes	1,3	0,74
L.060AC	60	69	Alu	Behind	no	yes	yes	1,36	1,09
L.060HF	60	60	Alu	Behind	no	yes	yes	1,23	1,32
L.065AL	65	70	Alu	Behind	no	yes	yes	1,26	0,68
L.066.01	66	76,5	Alu	Behind	no	yes	yes	1,27	0,71
L.066.06	66	73	Alu	Behind	no	yes	yes	1,34	0,44
L.066P	66	15	Alu	Behind	no	yes	yes	1,02	0,42
L.066S	66	76,5	Alu	Behind	no	yes	yes	1,28	0,74
L.066V	66	74	Alu	Behind	no	yes	yes	1,6	1,1
L.066CL	66	76,5	Alu	-	no	yes	yes	1,3	0,71
L.066IM1	66	76,5	Alu	Behind	no	yes	yes	1,3	0,71
L.075HF	75	76,5	Alu	Behind	no	yes	yes	1,27	0,71
L.075W	75	101	Alu	Behind	no	yes	yes	1,39	0,80
L.095.01	95	102,1	Alu	Behind	no	yes	yes	1,33	0,89
L.095S	95	101,1	Alu	Behind	no	yes	yes	1,33	0,89
L.120	120	120	Alu	Behind	no	yes	yes	1,21	0,85
L.150DAC	150	170	Alu	Behind	no	yes	yes	1,36	1,09
L.150ACS	150	239	Alu	Behind	no	not recommended	yes	1,36	1,09
L.150ACL	150	328	Alu	Behind	no	not recommended	yes	1,36	1,09
L.170DAC	170	170	Alu	Behind	no	yes	yes	1,36	1,09
L.170ACS	170	239	Alu	Behind	no	not recommended	yes	1,36	1,09
L.170ACL	170	328	Alu	Behind	no	not recommended	yes	1,36	1,09

The friction coefficient (determined using wind tunnel tests) indicates how the wind affects the blade.

C_{fy} = coefficient used to determine the horizontal load (drag) on a blade

C_{fz} = coefficient used to determine the vertical load (lift) on a blade

Visual free area [%]	Physical free area [%]	K-Factor				C _e -Coefficient		C _d -Coefficient		BLADE TYPE
		Supply without mesh	Supply with mesh	Exhaust without mesh	Exhaust with mesh	Supply without mesh	Supply with mesh	Exhaust without mesh	Exhaust with mesh	
59	44,7	22,68	26,30	25,25	25,51	0,210	0,195	0,199	0,198	L.033.01
56	26	-	123,46	-	118,15	-	0,090	-	0,092	L.033.08
59	50	22,46	23,11	25,25	25,51	0,211	0,208	0,199	0,198	L.033HF
59	43	61,04	66,1	61,04	66,1	0,128	0,123	0,128	0,123	L.033V
59	-	-	-	-	-	-	-	-	-	L.033CL
59	24	34,7	-	31,0	-	-	-	-	-	L.033IM1
70	49	12,57	13,42	8,91	11,73	0,282	0,273	0,335	0,292	L.050.00
50	32,5	15,69	-	16,33	-	0,252	-	0,247	-	L.050.25
70	60	8,75	9,41	8,86	9,47	0,338	0,326	0,336	0,325	L.050HF
70	-	-	-	-	-	-	-	-	-	L.050CL
70	57	10,47	10,47	16,52	16,52	0,309	0,309	0,246	0,246	L.050W
70	57	-	10,75	-	16,52	-	0,305	-	0,246	L.050WV
70	59	6,09	-	6,85	-	0,405	-	0,382	-	L.050WS
70	34,7	-	14,6	-	16,5	-	0,262	-	0,246	L.050IM1
70	46	-	13,32	-	13,92	-	0,274	-	0,268	L.050IM2
75	34	9,22	-	13,29	-	0,329	-	0,274	-	L.060AC
90	76	5,03	5,59	4,96	5,62	0,446	0,423	0,449	0,422	L.060HF
70	56	13,32	13,92	17,08	17,22	0,274	0,268	0,242	0,241	L.065AL
70	49,2	14,24	14,24	11,77	14,91	0,265	0,265	0,291	0,259	L.066.01
50	37,8	29,11	-	29,3	-	0,185	-	0,185	-	L.066.06
77	77	3,57	-	3,71	-	0,529	-	0,519	-	L.066P
70	49,2	13,62	-	14,62	-	0,271	-	0,262	-	L.066S
70	40,6	66,10	-	79,72	-	0,123	-	0,112	-	L.066V
70	-	-	-	-	-	-	-	-	-	L.066CL
70	32	16,66	-	-	-	0,245	-	-	-	L.066IM1
73	52	13,13	13,22	14,24	14,57	0,276	0,275	0,265	0,262	L.075HF
87	53	-	10,89	-	10,41	-	0,303	-	0,310	L.075W
86	55,5	12,40	12,40	11,65	11,65	0,293	0,293	0,284	0,284	L.095.01
86	55	9,7	-	9,4	-	0,321	-	0,326	-	L.095S
66	60	13,82	-	14,68	-	0,269	-	0,261	-	L.120
54	34,3	47,70	-	42,47	-	0,145	-	0,153	-	L.150DAC
54	34,3	38,58	38,58	35,01	35,01	0,161	0,161	0,169	0,169	L.150ACS
54	34,3	37,3	-	41,9	-	0,164	-	0,154	-	L.150ACL
59	37	41,08	-	37,58	-	0,156	-	0,163	-	L.170DAC
59	37	25,4	-	25,1	-	0,198	-	0,200	-	L.170ACS
59	37	28,58	-	30,88	-	0,187	-	0,180	-	L.170ACL

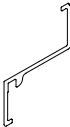
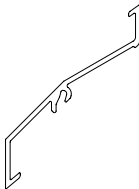
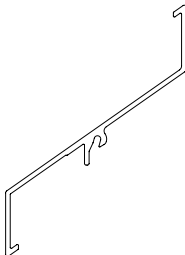
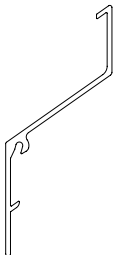
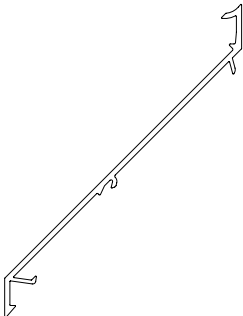
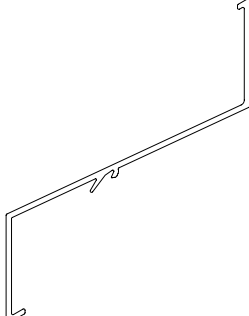
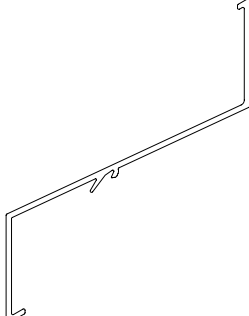
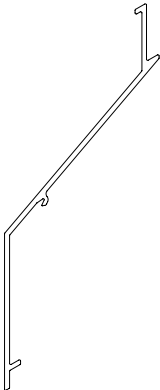
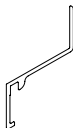
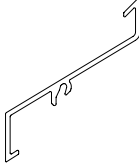
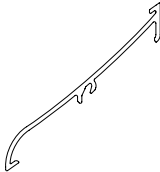
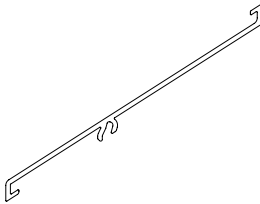
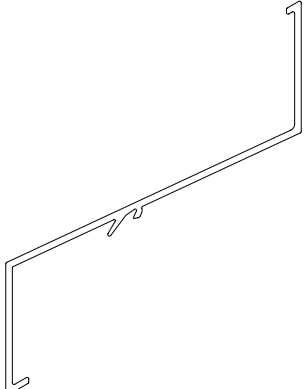

OVERVIEW BLADE TYPES

Extruded aluminium - standard blades			
Ref. L.033.01	Ref. L.050.00	Ref. L.066.01	Ref. L.066.06
Standard blade - p 18	Standard blade - p 28	Standard blade - p 50	Lamel met verlengde neus - p 50
			
Ref. L.095.01	Ref. L.120.01	Ref. L.120.01	Ref. L.150.DAC.01
Standard blade - p 64	Standard blade with large span - p 68	Standard blade with large span - p 68	Combinable blade with acoustic system - p 76
			
Extruded aluminium - Blades with large free area			
Ref. L.033HF	Ref. L.050HF	Ref. L.050WS	Ref. L.060HF
Blade with large free area - p 22	Blade with large free area - p 32	Combinable blade with high performance system - p 36	Blade with large free area - p 40
			
Ref. L.120.01			
Blade with large free area - p 68			
			

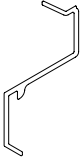
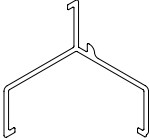
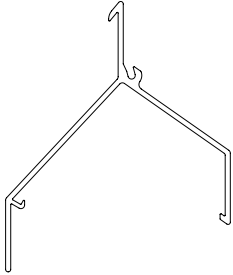
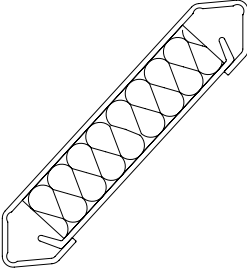
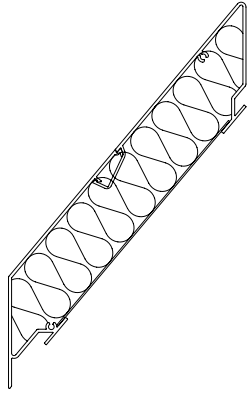
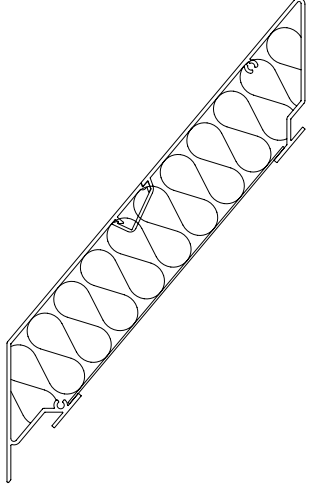
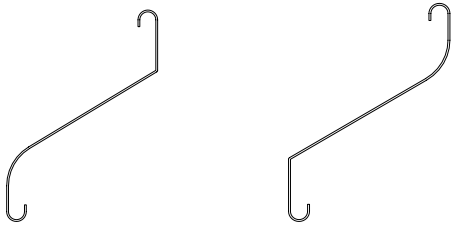

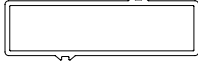
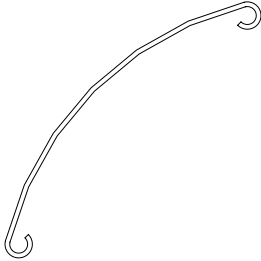
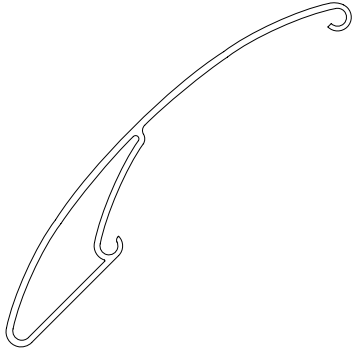
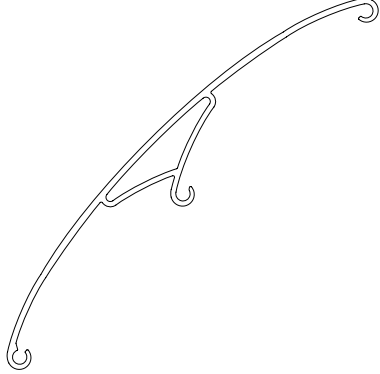
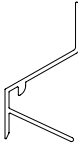
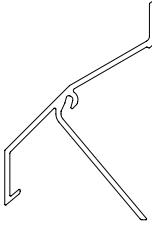
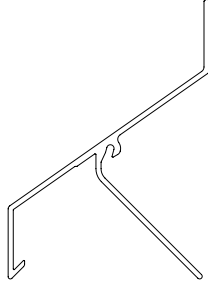
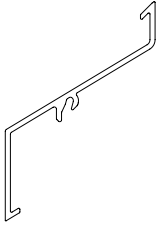
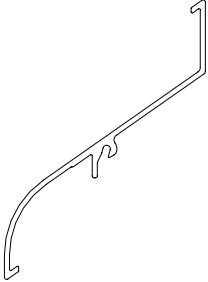
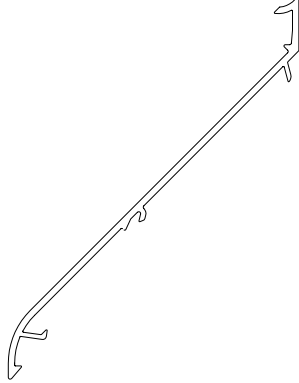

Extruded aluminium - blades for restricted access and visual screening		
Ref. L.033.08	Ref. L.033V	Ref. L.066V
Labyrinthe blade - p 26	V-blade - p 26	V-blade - p 54
		
Extruded aluminium - acoustic blades		
Ref. L.060AC	Ref. L.150ACS.01	Ref. L.150ACL.01
Acoustic blade - p 42	Acoustic blade - p 74	Acoustic blade - p 74
		
Rolled aluminium - rolled sheet blades		
Ref. L.065AL and L.065AL.02		
Aluminium - p 46		
		

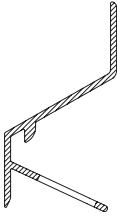
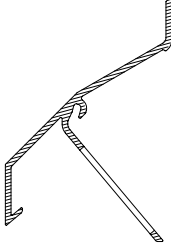
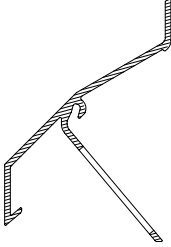
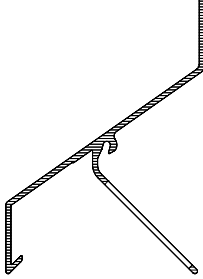
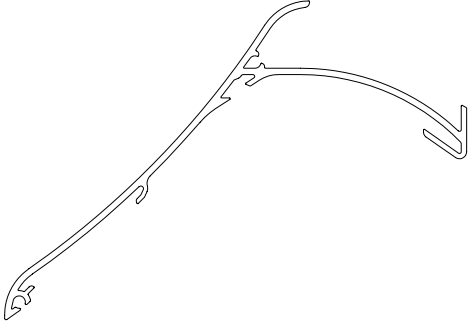
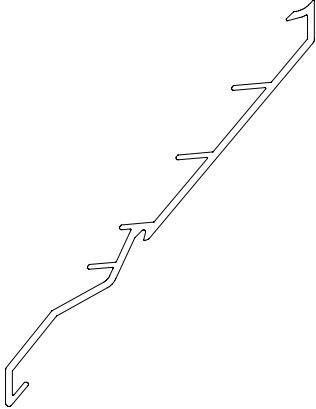
Extruded aluminium - aesthetic blades for cladding/sunprotection		
Ref. L.066P		
Rectangular blade - p 56		
		
Ref. SE.096	Ref. SE.130	Ref. SE.176
Aluminium - p 86	Aluminium - p 86	Aluminium - p 86
		
Extruded aluminium - closed blades		
Ref. L.033CL	Ref. L.050CL	Ref. L.066CL
Closed blade - p 24	Closed blade - p 34	Closed blade - p 52
		
Extruded aluminium - project profiles [*]		
Ref. L.050.25	Ref. L.066S	Ref. L.095S
Blade with extended nose - p 32	Blade soft line - p 50	Blade soft line - p 68
		

[*] = Project profiles not in stock

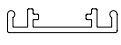
Extruded aluminium – with integrated insect mesh			
Ref. L.033IM1	Ref. L.050IM1	Ref. L.050IM2	Ref. L.066 IM1
Blade with integrated insect mesh - p 24	Blade with integrated insect mesh - p 34	Blade with integrated insect mesh - p 34	Blade with integrated insect mesh - p 52
			
Weatherable blade			
Ref. Extreme L.050W / L.050WV		Ref. L.075W	
High performance blade - p 36		Excellent weatherability for exhaust applications - p 60	
			

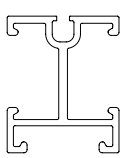
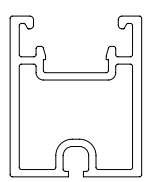
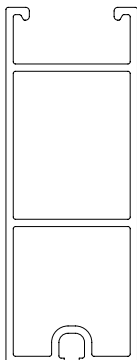
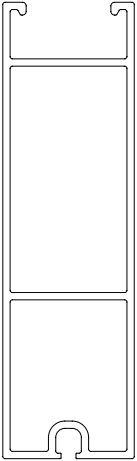
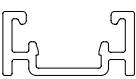
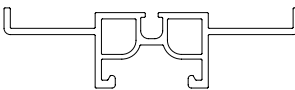
OVERVIEW SUPPORTING STRUCTURES

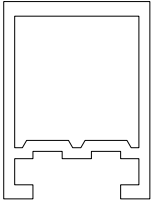
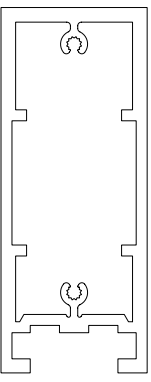
Supporting structure Linius®					
Ref.LD.0065	Ref.LD.0070	Ref. LD.0440	Ref.LD.0460	Ref. LD.0995	Ref. LD.1250
Continuous support - p 92	Continuous support - p 92	For constructions and sideways fixation - p 92	Medium vertical span - p 92	Large vertical span - p 92	For extra large unsupported spans - p 92
					
Ref.LD.0195			Ref. LD.0240		
Limited vertical span - p 92			For lateral fixation of mesh - p 92		
					
Supporting structure Sunclips®					
Ref. LD.0108	Ref. SD.014	Ref. SD.054	Ref. SD.100		
Adapter profile - p 92	Continuous support - p 92	Medium vertical span - p 92	Large vertical span - p 92		
					

L.033



Linus® L.033CL



Linus® L.033.01



Linus® L.033.01

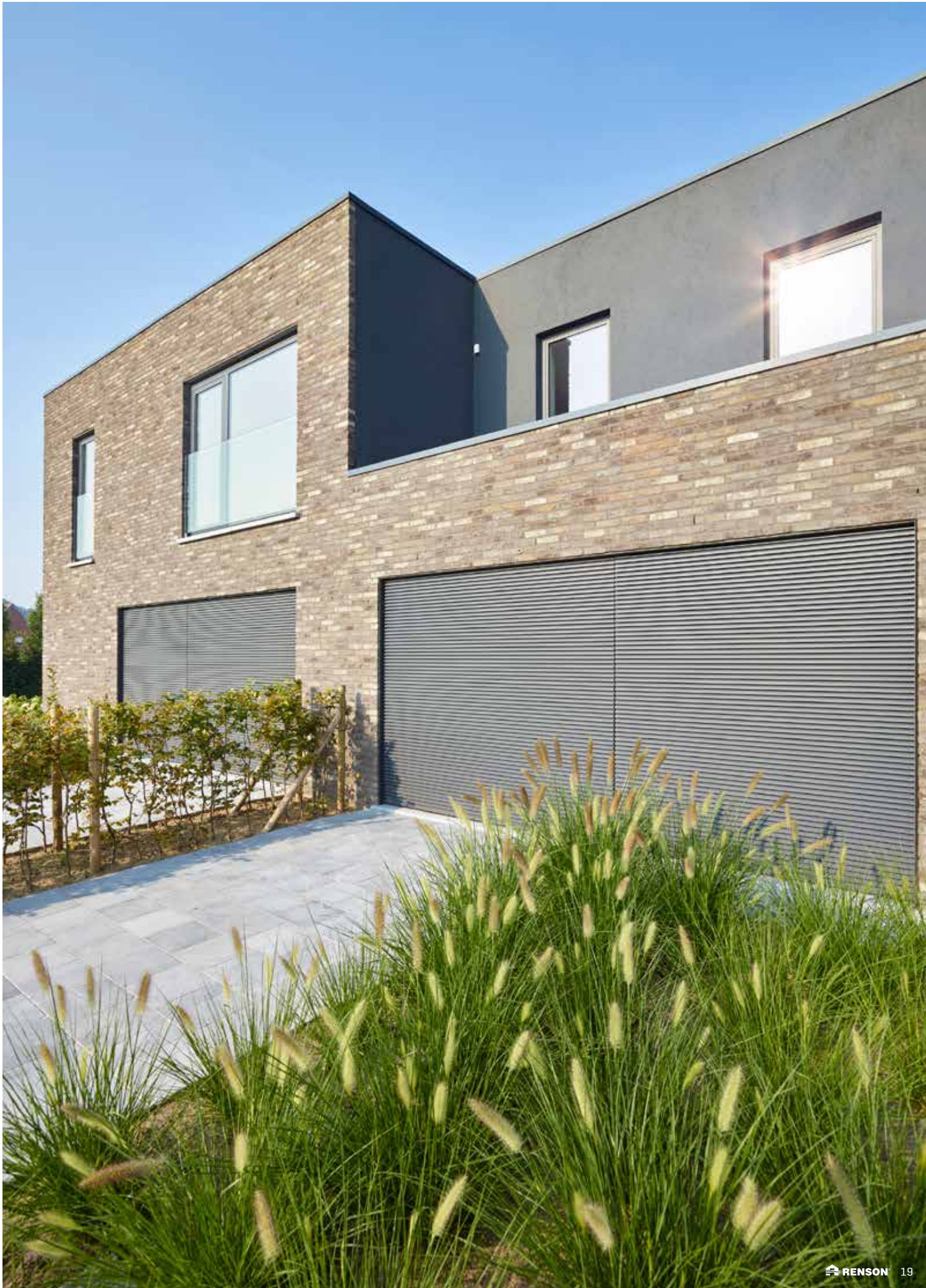

L.033.01

Extruded aluminium blade

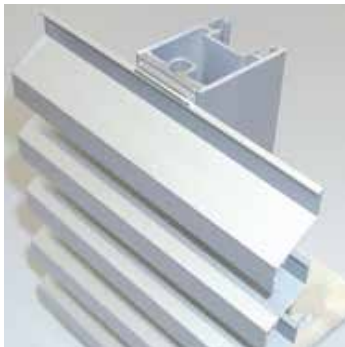
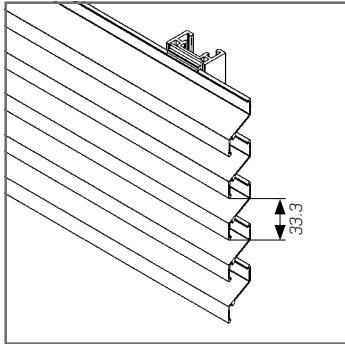

Extruded aluminium profile for light duty with a 33.3 mm pitch. Normally used for smaller surface areas.

MATERIALS

Aluminium extrusion, alloy EN AW 6063 T66

FINISH

- Anodised [20 micron]
- Polyester powder coating RAL or Syntha Pulvin colours [60 - 80 µ/40 µ (UK)]

MESH

Fixed to rear of the support structure or in combination with blade L.033IM1.

FEATURES

Blade L.033.01 can also be curved with a minimum radius of 800 mm [see p. 111]. Top blade L.033.02 available for attractive top connection. Long bottom blade L.033.03 and short bottom blade L.033.04 for optimal finish.

DOORS

Single and double doors available with standard Renson® hardware and rotating on pivot [see p. 106]

BLADE SUPPORT

- Single blade support: type L.033.11 (width: 30 mm)
- Double blade support for thermal expansion: type L.033.12 (width: 34 mm) [connecting piece for 2 blades]

TECHNICAL DATA

	L.033.01	L.033.02	L.033.03	L.033.04
Pitch	33,3 mm	33,3 mm	33,3 mm	33,3 mm
Depth	20,4 mm			
Height	37,5 mm	43 mm	49,5 mm	30 mm
K-Factor*, supply	22,68			
Visual free area*	59%			
Physical free area*	44,7%			
Max. unsupported span between two mullions**	800 mm			

* Definition see p. 6

** At q_p 800 Pa wind pressure

TECHNICAL DRAWINGS

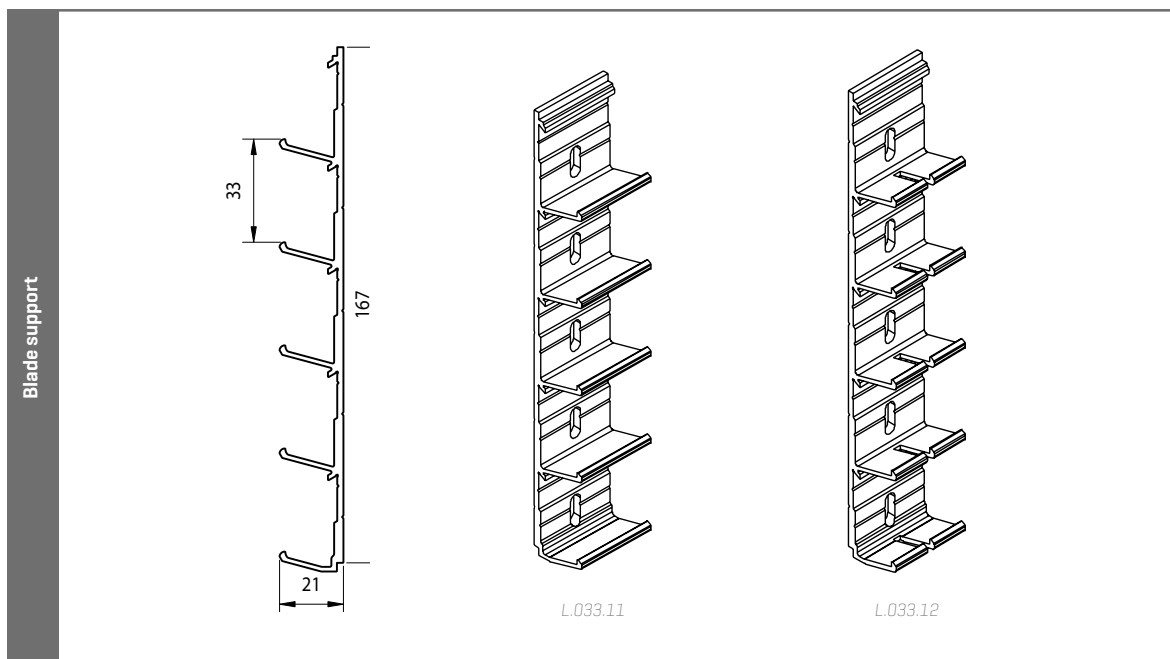
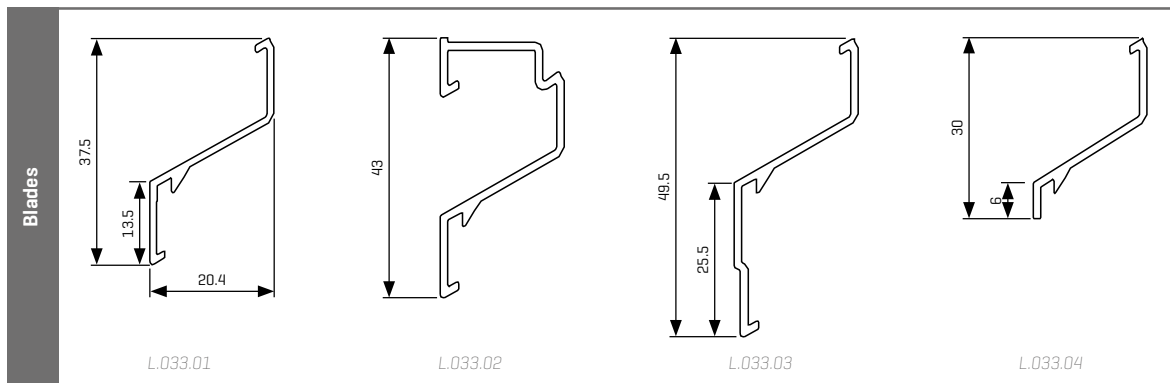

L.033 HF

Extruded aluminium blade

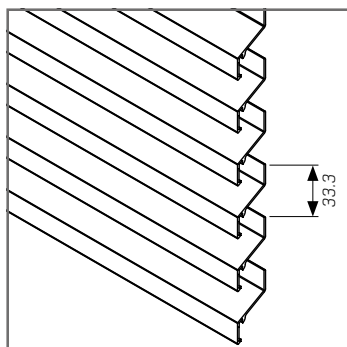

MATERIALS

Aluminium extrusion, alloy EN AW 6063 T66

FINISH

- Anodised (20 micron)
- Polyester powder coating RAL or Syntha Pulvin colours (60 - 80 µ/40 µ [UK])

MESH

Fixed to the support structure

FEATURES

Blade L.033HF can also be curved with a minimum radius of 800 mm [see p. 111].

DOORS

Single and double doors available with standard Renson® hardware and rotating on pivot [see p. 106]

BLADE SUPPORT

- Single blade support: L.033.11 (width: 30 mm)
- Double blade support for thermal expansion: L.033.12 (width: 34 mm) [connecting piece for 2 blades]

TECHNICAL DATA

L.033HF	
Pitch	33,3 mm
Depth	20,4 mm
Height	37,5 mm
K-Factor*, supply	22,46
Visual free area*	59 %
Physical free area*	50 %
Max. unsupported span between two mullions**	800 mm

* Definition see p. 6

** At q_p 800 Pa wind pressure

TECHNICAL DRAWINGS

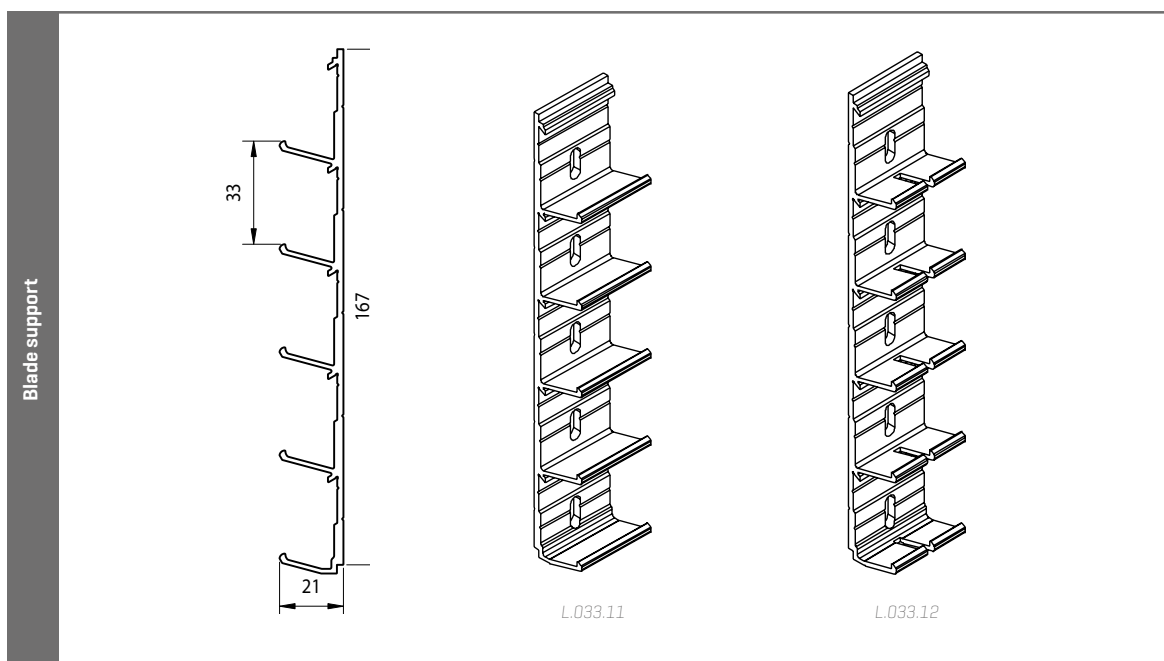
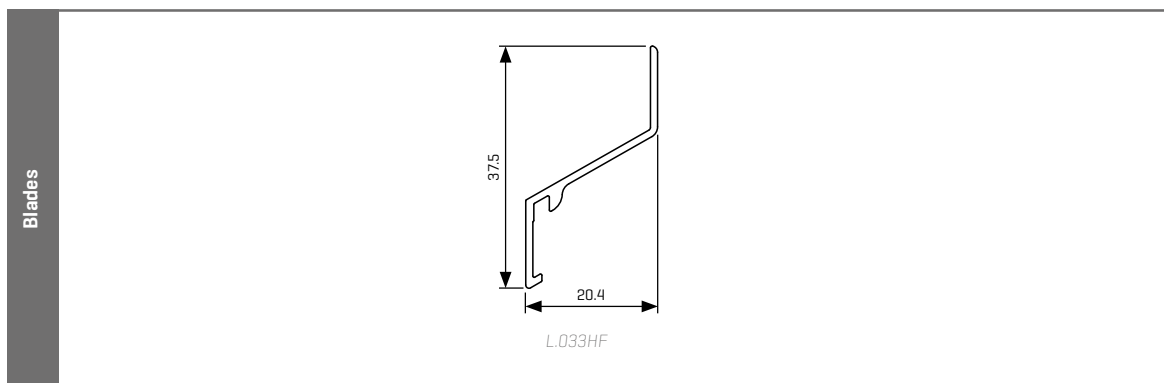

L.033CL / L.033IM1

Extruded aluminium blade

Installation
up to **2x**
faster

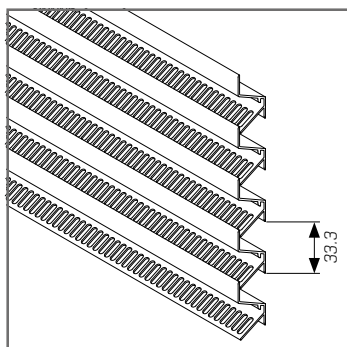

L.033IM1

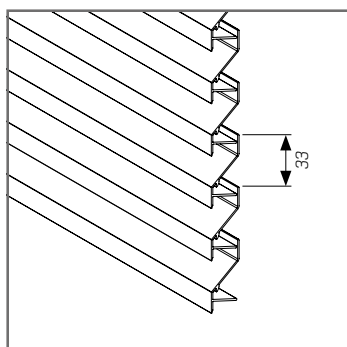

L.033CL

L.033CL

Suitable for fully or partially closed continuous louvre systems

L.033IM1

Extruded aluminium profile with integrated insect mesh. This 33.3 mm pitch blade clipped into the standard blade support combines weather resistance and insect protection. No separate insect mesh is needed, resulting in considerable time savings during installation. This blade is also the ideal solution for applications where installation of a separate insect mesh is difficult. The L.033IM1 blade combines perfectly with the standard L.033.01 blade and L.033CL closed blade.

MATERIALS

Aluminium extrusion, alloy EN AW 6063 T66.

FINISH

- Anodised [20 micron]
- Polyester powder coating RAL or Syntha Pulvin colours [60 - 80 µ/40 µ [UK]]

FEATURES

Top blade L.033CL.02 available.

DOORS

Single and double doors available with standard Renson® hardware and rotating on pivot [see p. 106].

BLADE SUPPORT

- Single blade support: L.033.11 (width: 30 mm)
- Double blade support for thermal expansion: L.033.12 (width: 34 mm) [connecting piece for 2 blades]
- The blade supports are the same for all L.033 blade types. They are only fitted upside down for blade type L.033V.

TECHNICAL DATA

	L.033IM1	L.033CL
Pitch	33,3 mm	33,3 mm
Depth	20,4 mm	20,4 mm
Height	38,2 mm	38,2 mm
K-Factor*, supply	34,7	-
Visual free area*	59 %	-
Physical free area*	24 %	-
Max. unsupported span between two mullions**	1350 mm	1400 mm

* Definition see p. 6

** At q_p 800 Pa wind pressure

TECHNICAL DRAWINGS

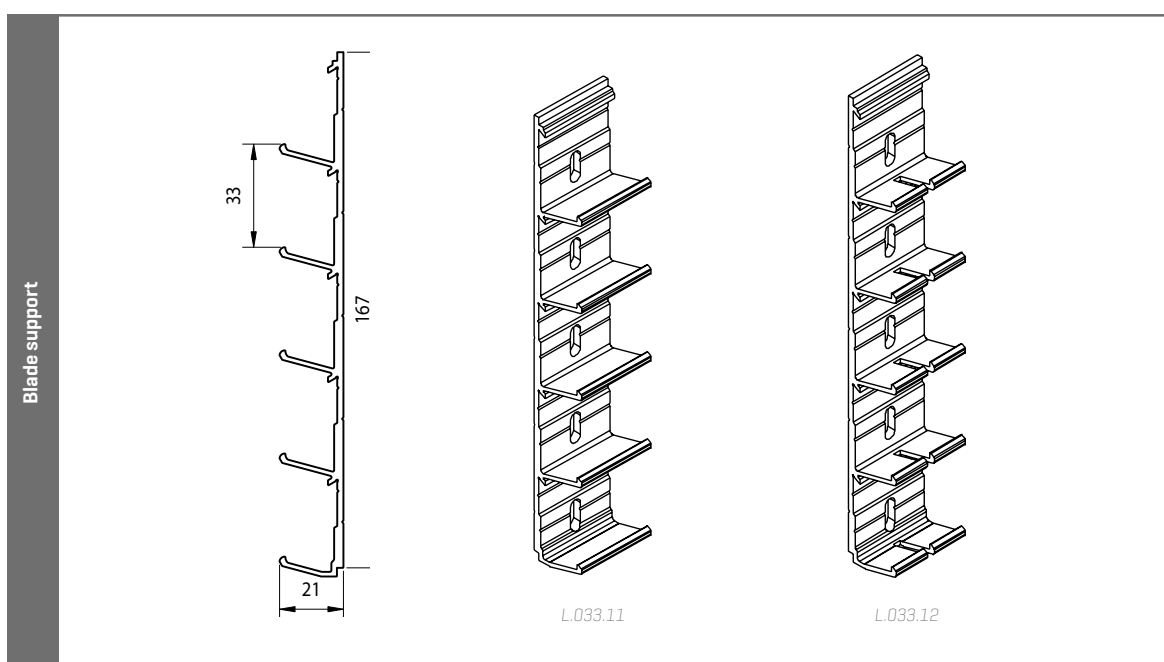
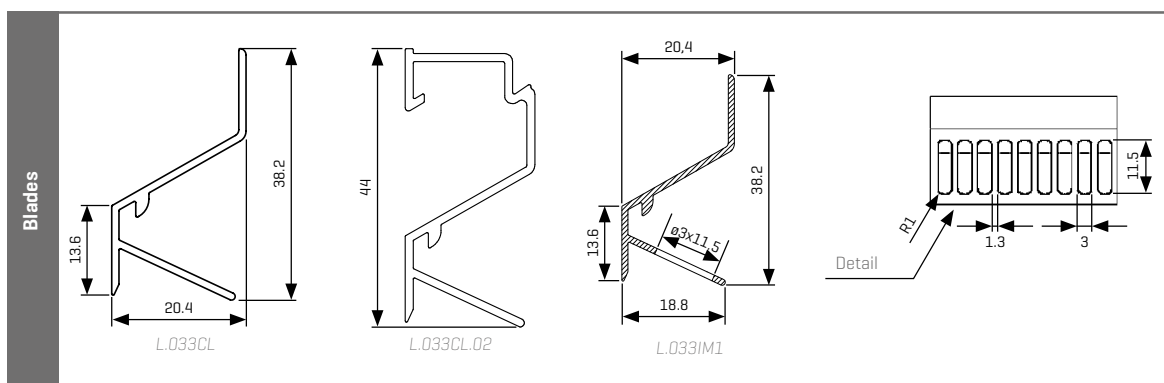

L.033V / L.033.08

Extruded aluminium blade

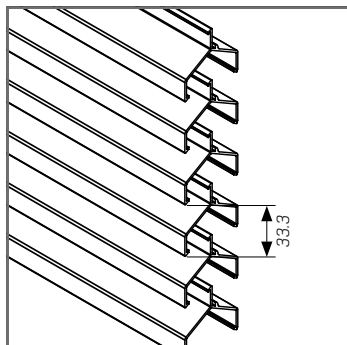

L.033.V

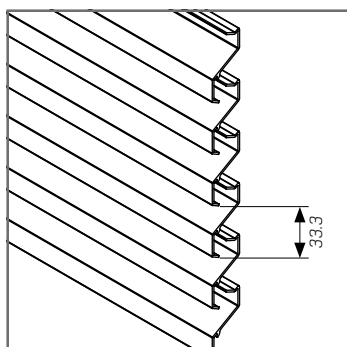

L.033.08

High-risk applications, such as high voltage units requiring restricted access.

Small format for high weather resistance.

Blade L.033V can be used together with blade L.033.01 thanks to their identical appearance.

MATERIALS

Aluminium extrusion, alloy EN AW 6063 T66

FINISH

- Anodised (20 micron)
- Polyester powder coating RAL or Syntha Pulvin colours (60 - 80 µ/40 µ [UK])

DOORS

Single and double doors available with standard Renson® hardware and rotating on pivot (see p. 106)

BLADE SUPPORT

- Single blade support: L.033.11 (width: 30 mm)
- Double blade support for thermal expansion: L.033.12 (width: 34 mm) (connecting piece for 2 blades)

TECHNICAL DATA

	L.033V	L.033.08
Pitch	33,3 mm	33,3 mm
Depth x Height	39,6 mm x 37,6 mm	20,4 mm x 42,3 mm
K-Factor*, supply	61,04	123,46
Visual free area*	60 %	56 %
Physical free area*	43 %	26 %
Max. unsupported span between two mullions**	800 mm	950 mm

* Definition see p. 6

** At q_p 800 Pa wind pressure

TECHNICAL DRAWINGS

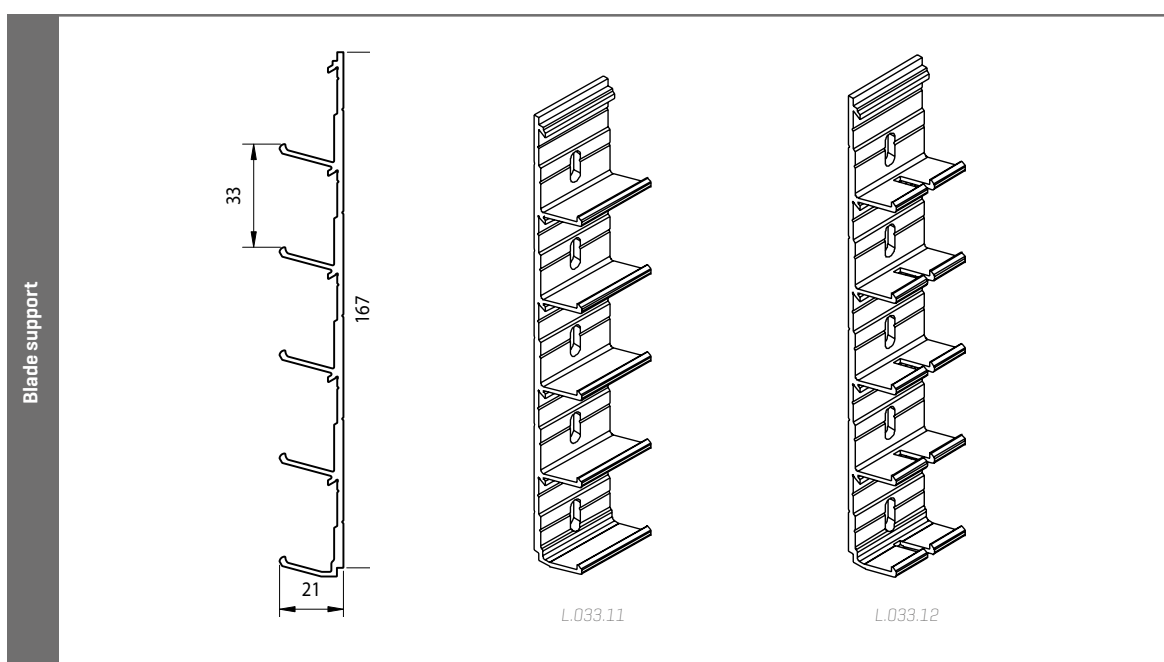
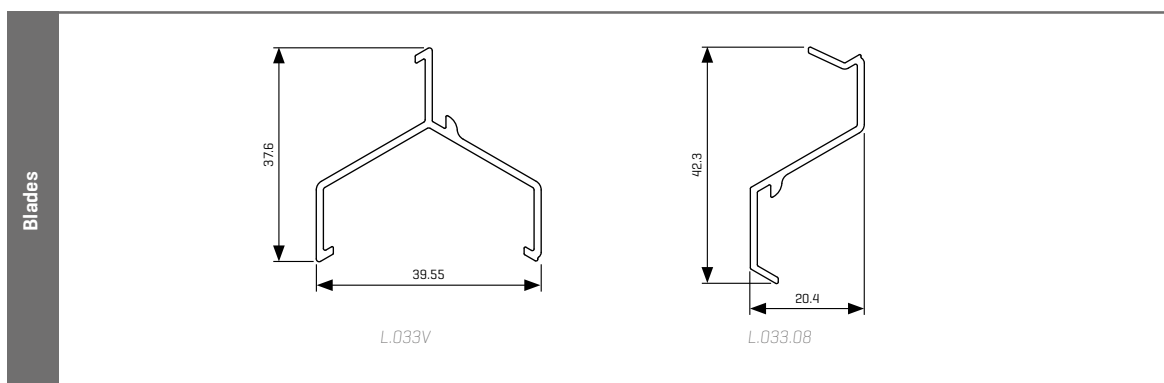

L.050



Linius® L.050.00



Linius® L.050.07



Linius® L.050.01



L.050.00

Extruded aluminium blade

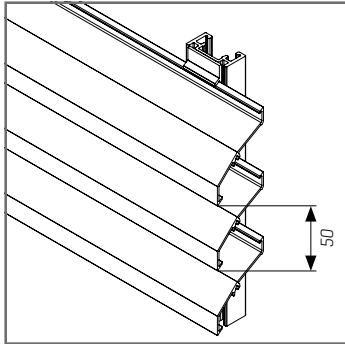

Heavy-duty extruded aluminium profile at 50 mm pitch with very high air flow. Variable 50 to 100 mm pitch is possible with blade supports of the type L.050.13 and L.050.14 [see drawing below].

MATERIALS

Aluminium extrusion, alloy EN AW 6063 T66

FINISH

- Anodised [20 micron]
- Polyester powder coating RAL or Syntha Pulvin colours (60 - 80 µ/40 µ [UK])

MESH

Fixed to rear of the support structure. of in combinatie met lamel L.050IM1 or L.050IM2.

FEATURES

Blade L.050.00 can also be curved with a minimum radius of 800 mm [see p. 111]. Top blade L.050.02 available for attractive top connection. Long bottom blade L.050.03 and short bottom blade L.050.04 for optimal finish.

DOORS

Single and double doors available with standard Renson® hardware and rotating on pivot [see p. 106].

BLADE SUPPORT

- Blade supports for 50 mm pitch
 - Single blade support: type L.050.11 (width 28 mm)
 - Double blade support for thermal expansion: type L.050.12 (width 34 mm) (connection piece for 2 blades)
- Blade supports for variable pitch 50 - 100 mm
 - Single blade support: type L.050.13 (width 28 mm)
 - Double blade support for thermal expansion: types L.050.14 (width 34 mm) (connection piece for 2 blades)

TECHNICAL DATA

L.050.00	
Pitch	50 mm
Depth	41,0 mm
Height	56,0 mm
K-Factor*, supply	12,57
Visual free area*	70%
Physical free area*	49%
Max. unsupported span between two mullions**	1200 mm

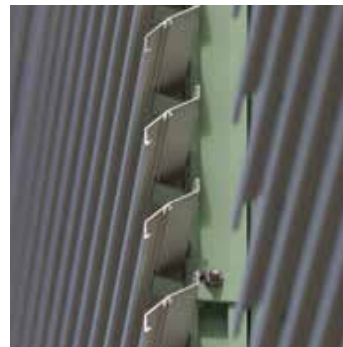

* Definition see p. 6
 ** At q_p 800 Pa wind pressure

TECHNICAL DRAWINGS

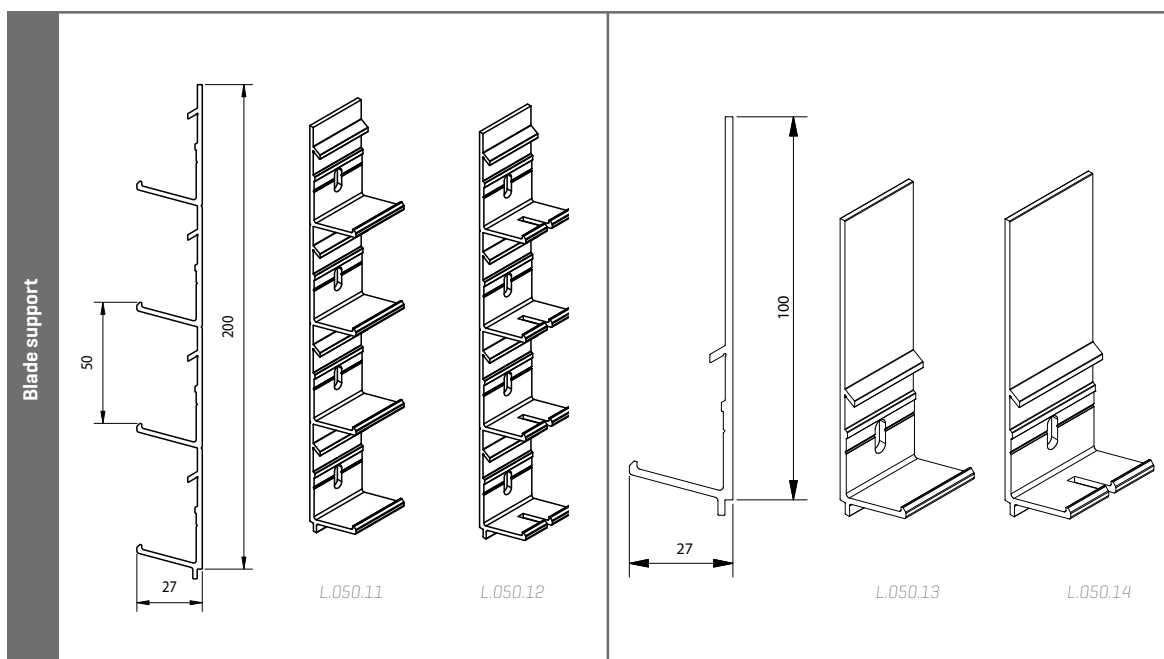
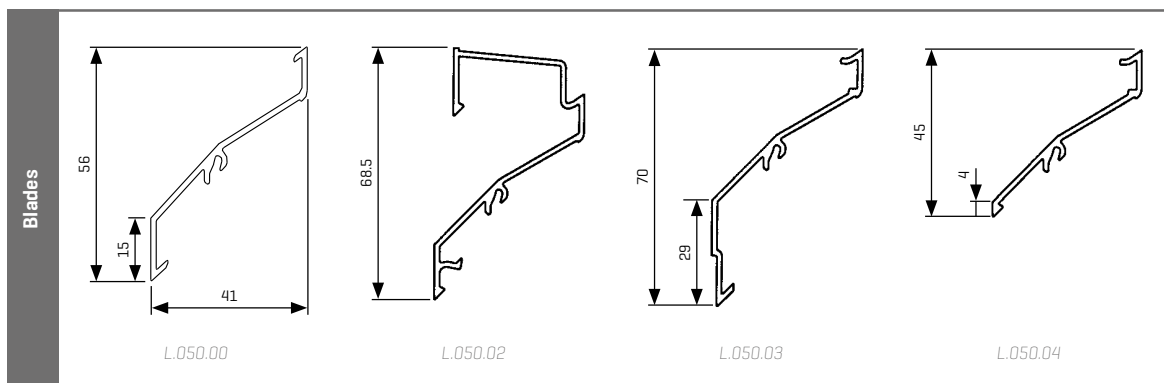

L.050HF / L.050.25

Extruded aluminium blade

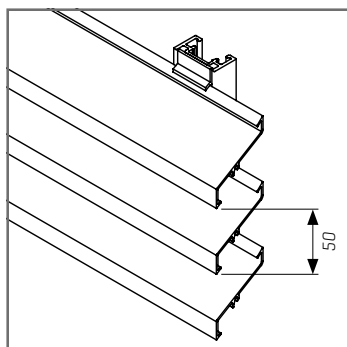

L.050HF

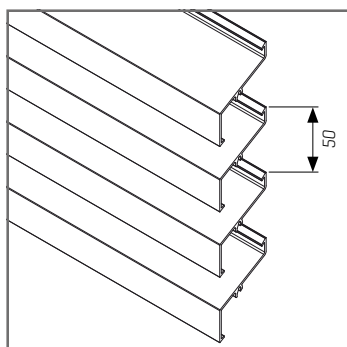

L.050.25

L.050HF

Heavy-duty extruded aluminium profile at 50 mm pitch with very high air flow. Variable 50 to 100 mm pitch is possible with blade supports of the type L.050.13 and L.050.14. Often to be found where the blade pitch reflects the aesthetics of the overall project design.

L.050.25

Project blade with extended front side

MATERIALS

Aluminium extrusion, alloy EN AW 6063 T66

FINISH

- Anodised [20 micron]
- Polyester powder coating RAL or Syntha Pulvin colours (60 - 80 µ/40 µ [UK])

MESH

Fixed to rear of the support structure.

FEATURES

Blade L.050HF can also be curved with a minimum radius of 800 mm [see p. 111].

DOORS

Single and double doors available with standard Renson® hardware and rotating on pivot [see p. 106]

BLADE SUPPORT

- Blade supports for 50 mm pitch
 - Single blade support: type L.050.11 (width 28 mm)
 - Double blade support for thermal expansion: type L.050.12 (width 34 mm) [connection piece for 2 blades]
- Blade supports for variable pitch 50 - 100 mm
 - Single blade support: type L.050.13 (width 28 mm)
 - Double blade support for thermal expansion: type L.050.14 (width 34 mm) [connecting piece for 2 blades]

TECHNICAL DATA

	L.050HF	L.050.25
Pitch	50 mm	50 mm
Depth	41,0 mm	41,0 mm
Height	50,0 mm	60,0 mm
K-Factor*, supply	8,75	15,69
Visual free area*	70%	50%
Physical free area*	60%	32,5%
Max. unsupported span between two mullions**	1050 mm	1300 mm

* Definition see p. 6

** At q_p 800 Pa wind pressure

TECHNICAL DRAWINGS

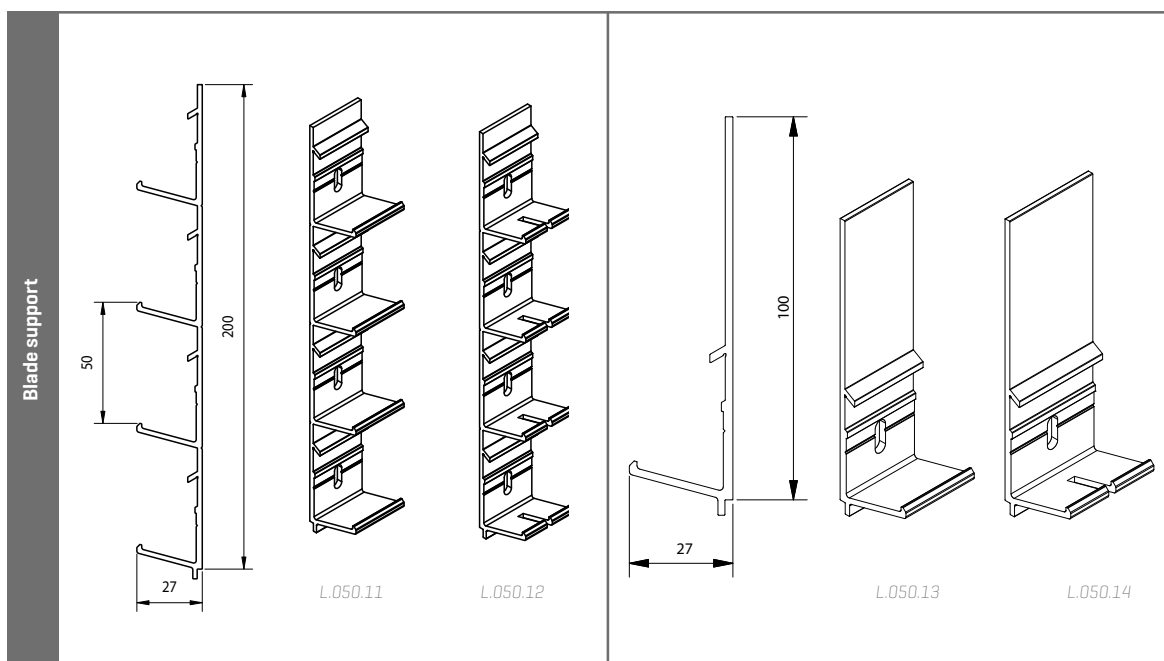
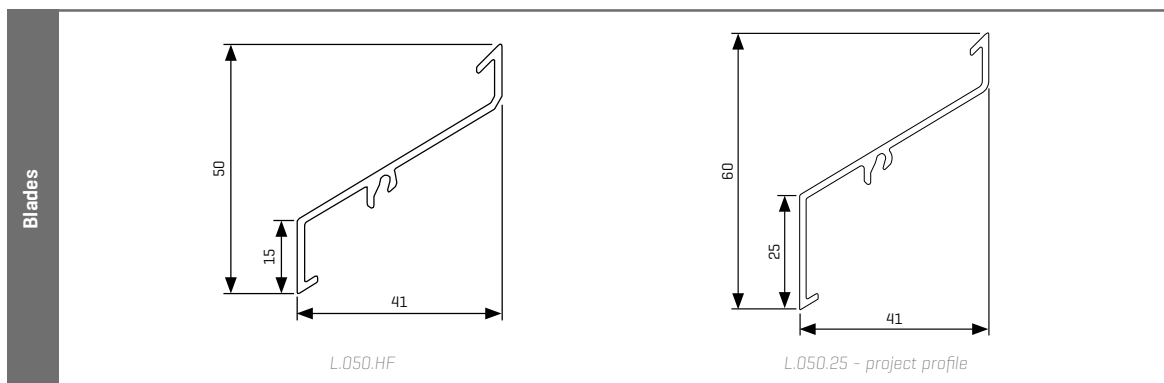

L.050CL / L.050IM1 / L.050IM2

Extruded aluminium blade

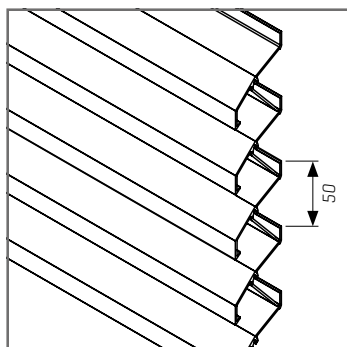

L.050CL

L.050CL

Often used in cases where the step between the blades display the aesthetics of the project design.

L.050CL - Suitable for fully or partially closed continuous louver systems.

L.050IM1 / L.050IM2

Extruded aluminium profile with integrated insect mesh (L.050IM1) or integrated bird mesh (L.050IM2). This 50 mm pitch blade clipped into the standard blade, offers good weather resistance and prevents insects/birds from entering. No separate mesh is needed, resulting in considerable time savings during installation. This blade is also the ideal solution for applications where installation of a separate insect mesh is difficult. The L.050IM1 or L.050IM2 blade combines perfectly with the standard L.050.00 blade and L.050CL closed blade.

MATERIALS

Aluminium extrusion, alloy EN AW 6063 T66

FINISH

- Anodised (20 micron)
- Polyester powder coating RAL or Syntha Pulvin colours (60 - 80 µ/40 µ [UK])

DOORS

Single and double doors available with standard Renson® hardware and rotating on pivot [see p. 106].

BLADE SUPPORT

- Single blade support: type L.050.11 (width: 28 mm)
- Double blade support for thermal expansion: L.050.12 (width: 34 mm) [connecting piece for 2 blades]

Installation
up to **2x**
faster

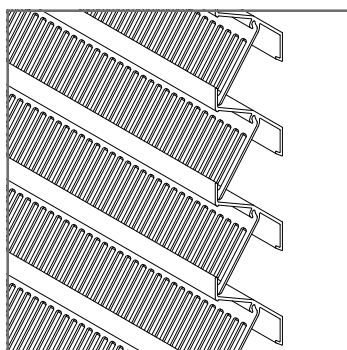

L.050IM1

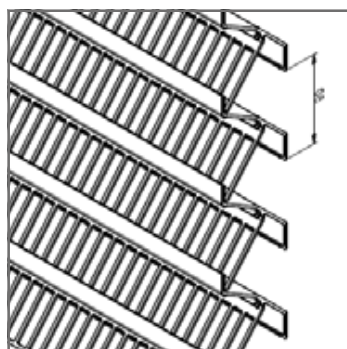

L.050IM2

TECHNICAL DATA

	L.050CL	L.050IM1	L.050IM2
Pitch	50 mm	50 mm	50 mm
Depth	41 mm	41 mm	41 mm
Height	60 mm	60 mm	60 mm
K-Factor*, supply		14,59	13,32
Visual free area*		70 %	70 %
Physical free area*		34,7 %	46 %
Max. unsupported span between two mullions**	2100 mm	2100 mm	2100 mm
Weatherability	-	0,0 m/s 8,51 % C 0,5 m/s 13,14 % C 1,0 m/s 16,8 % C 1,5 m/s 20,66 % D	0,0 m/s 13,35 % C 0,5 m/s 19,16 % C 1,0 m/s 22,42 % D

* Definition see p. 6

** At q_p 800 Pa wind pressure

TECHNICAL DRAWINGS

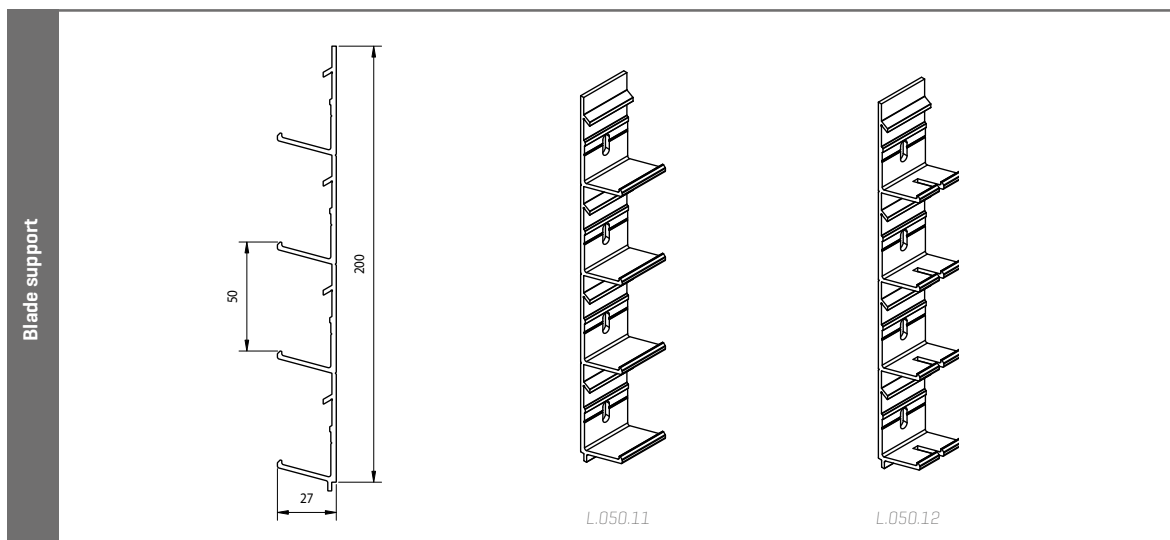
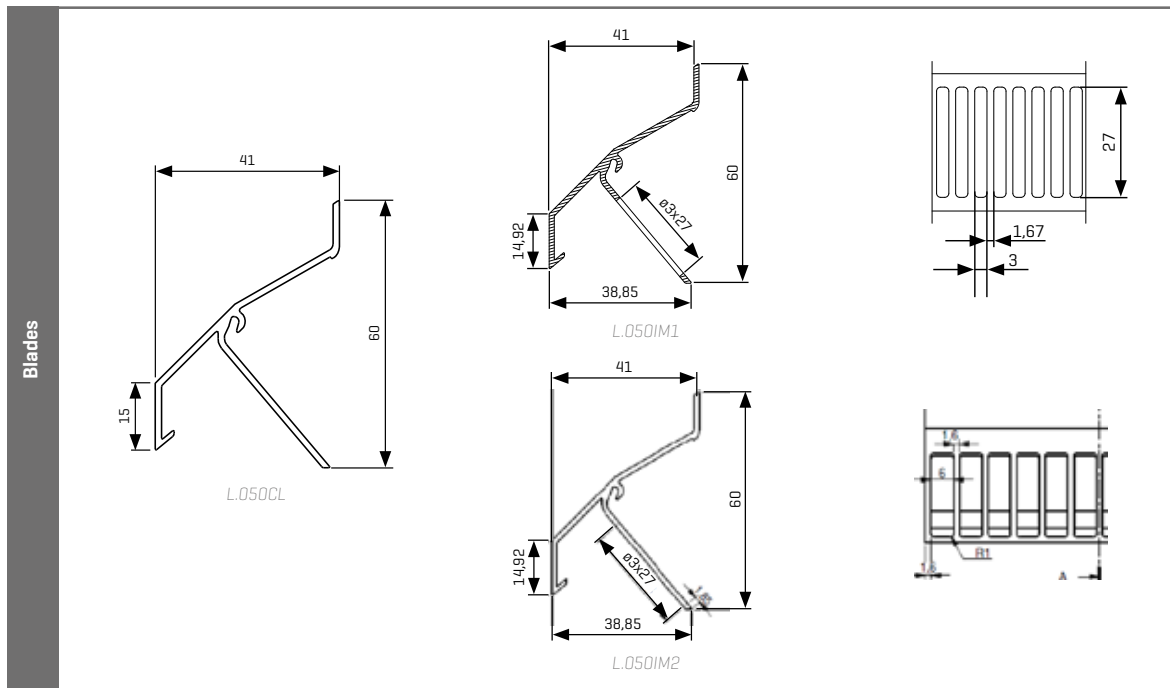

L.050W / L.050WV / L.050WS

Extruded aluminium blade

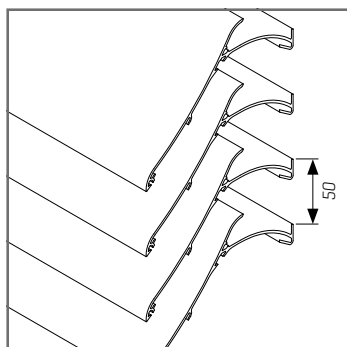

L.050W

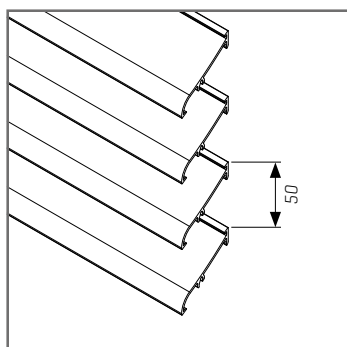

L.050WS

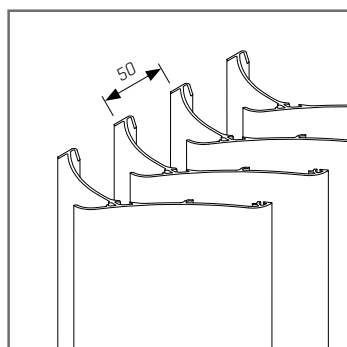

L.050WV

L.050W

The new patented system Renson® Linius L.050W is an aesthetically elegant high performance louvre. The system consists of water-resistant blades which have been tested up to 3.0 m/s according to performance class A2 [L.050WV: class A2 to 4,0 m/s]. They are easy to install and barely visible, thanks to being clip mounted to blade supports which accompany the system. Other unique features of this system include excellent air flow, a good physical free area and the blade's large unsupported span between two mullions. This system L.050W can be provided with an optional frame profile L.050W.23 - see Aluminium frames.

L.050WS

To provide a matching aesthetic blade, the L.050WS blade is available as part of the system. The blade can be used for non active areas or where high performance without weather resistance is required. Visually the two systems appear the same.

MATERIALS

Aluminium extrusion, alloy EN AW 6063 T66

FINISH

- Anodised [20 micron]
- Polyester powder coating RAL or Syntha Pulvin colours [60 - 80 µ/40 µ (UK)]

MESH

Fixed to rear of the support structure.

BLADE SUPPORT L.050W

- Blade support: type L.050W.11 [width: 34 mm]

BLADE SUPPORT L.050WS

- Single blade support: type L.050.11
- Double blade support for thermal expansion: type L.050.12

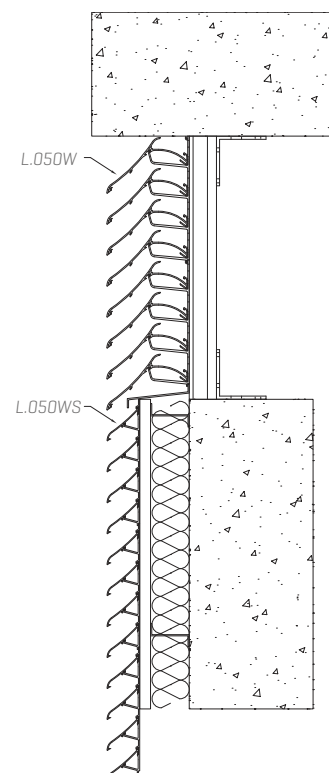

TECHNICAL DATA

	L.050W	L.050WV	L.050WS
Pitch	50 mm	50 mm	50 mm
Depth	130 mm	130 mm	50 mm
Height	90 mm	90 mm	55 mm
Watertightness ***	A2 to 3,0m/s	A2 (4 m/s)	-
Physical free area	57%	57%	59%
K-Factor*, supply	10,47	10,75	6,09
C _q -coefficient	0,309	0,305	0,405
C _i -coefficient	0,246	0,246	0,382
Max. unsupported span between two mullions**	1420 mm	1420 mm	950 mm

* Definition see p. 6

** At q_p 800 Pa wind pressure

*** Execution with mesh 2,3 x 2,3 mm

TECHNICAL DRAWINGS

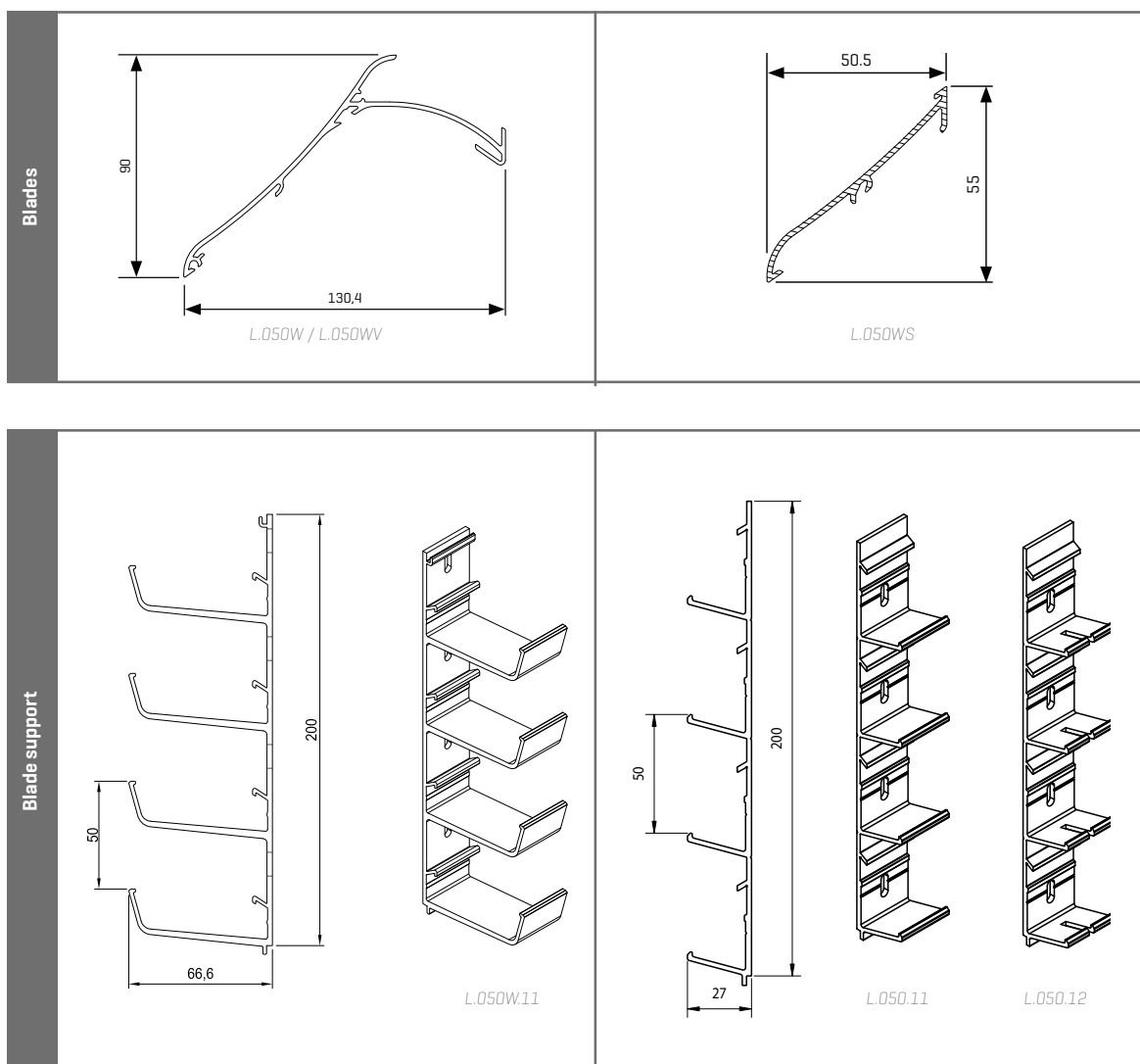

L.060





L.060HF

Extruded aluminium blade

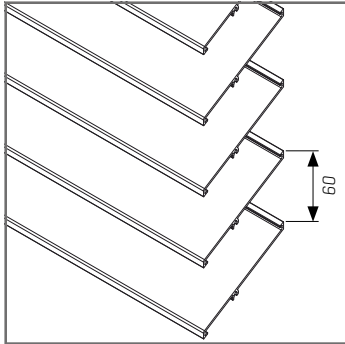

Extruded aluminium louvre profile with minimal air flow resistance. Particularly suitable where a large airflow is required in combination with considerable optical density and a sharp design.

MATERIALS

Aluminium extrusion, alloy EN AW 6063 T66

FINISH

- Anodised [20 micron]
- Polyester powder coating RAL or Syntha Pulvin colours [60 - 80 µ/40 µ (UK)]

MESH

Fixed to rear of the support structure.

DOORS

Single and double doors available with standard Renson® hardware and rotating on pivot [see p. 106]

BLADE SUPPORT

- Single blade support: type L.060HF.11 [width 28 mm]
- Double blade support for thermal expansion:
L.060HF.12 [connecting piece for 2 blades] [width 34 mm]

TECHNICAL DATA

	L.060HF
Pitch	60 mm
Depth	78 mm
Height	60 mm
K-Factor*, supply	5,03
K-Factor*, extraction	4,96
Visual free area*	90%
Physical free area*	76%
Max. unsupported span between two mullions**	650 mm

* Definition see p. 6

** At q_p 800 Pa wind pressure



TECHNICAL DRAWINGS

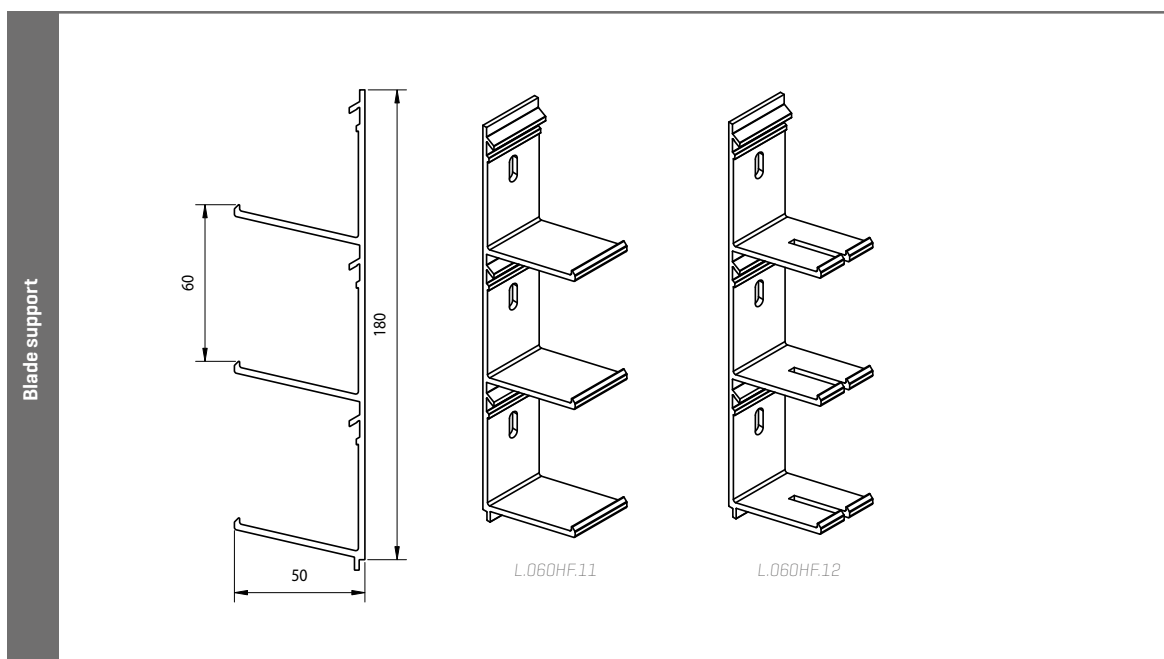
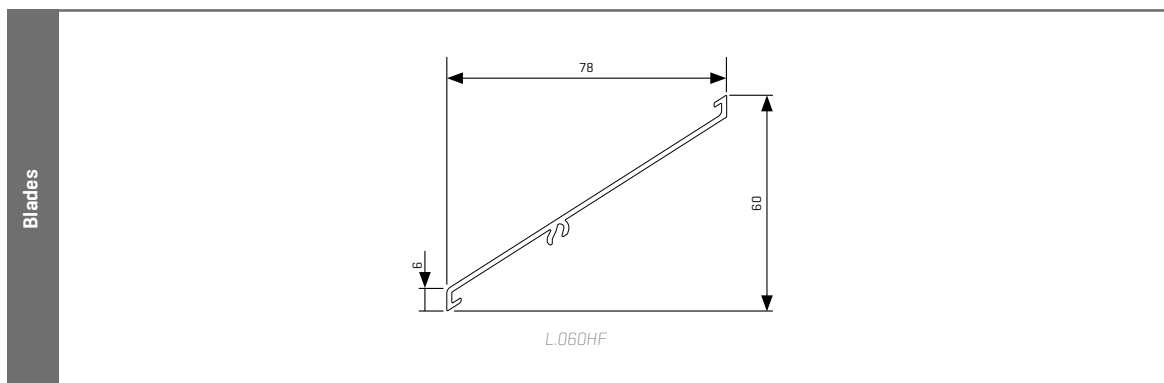

L.060AC

Extruded aluminium acoustic blade

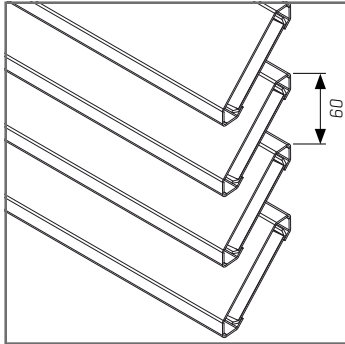

Extruded aluminium profile with a pitch of 60 mm and perforated back; maximum blade length of 6,000 mm. Blades packed with inorganic mineral wool for acoustic performance. Developed to provide an aesthetic solution for noise reducing continuous louvre applications.

MATERIALS

- Extruded aluminium, EN AW-6063 T66, mineral wool, perforated PVC strip.

FINISH

- Anodised (20 micron)
- Polyester powder coating RAL or Syntha Pulvin colours (60 - 80 μ /40 μ [UK])

MESH

Fixed to rear of the support structure.

DOORS

Single and double doors available with standard Renson® hardware and rotating on pivot [see p. 106]

ACOUSTIC PROPERTIES

L.060AC: $R_w [C;C_p] = 6 [-1; -2]$ dB

BLADE SUPPORT

- Single blade support: type L.060AC.11 (width: 28 mm)
- Double blade support for thermal expansion:
L.060AC.12 (width: 45 mm) (connecting piece for 2 blades)

TECHNICAL DATA

L.060AC	
Pitch	60 mm
Depth	64 mm
Height	69 mm
K-Factor*	9,22
Visual free area*	75 %
Physical free area*	34 %
Max. unsupported span between two mullions**	1700 mm

* Definition see p. 6

** At q_p 800 Pa wind pressure

TECHNICAL DRAWINGS

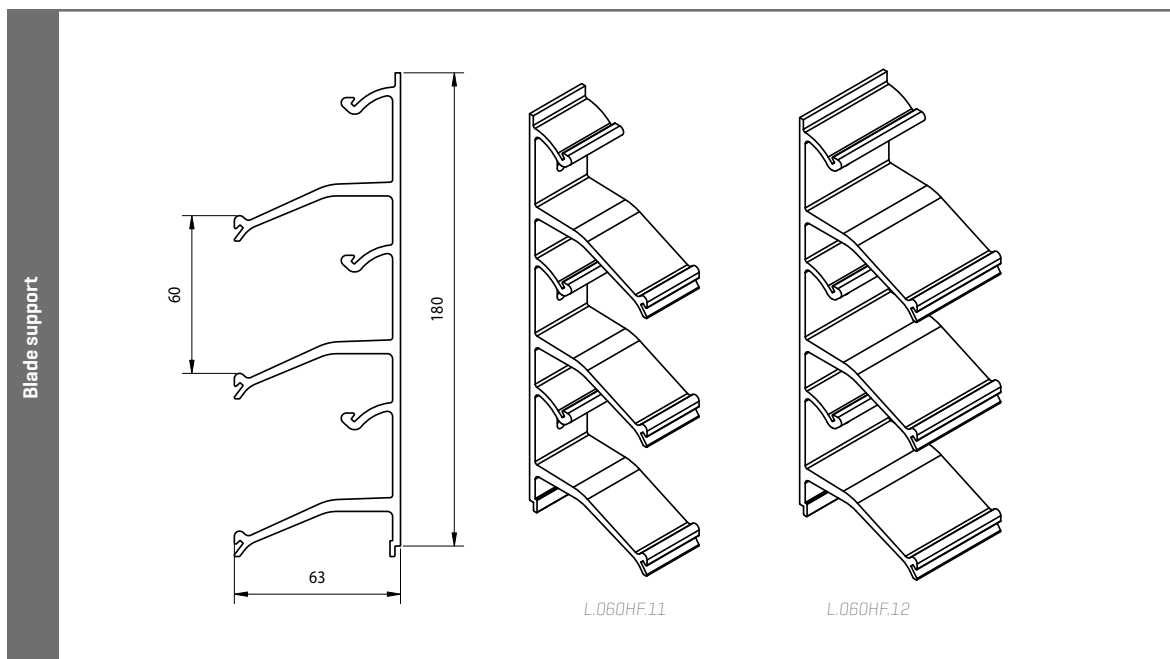
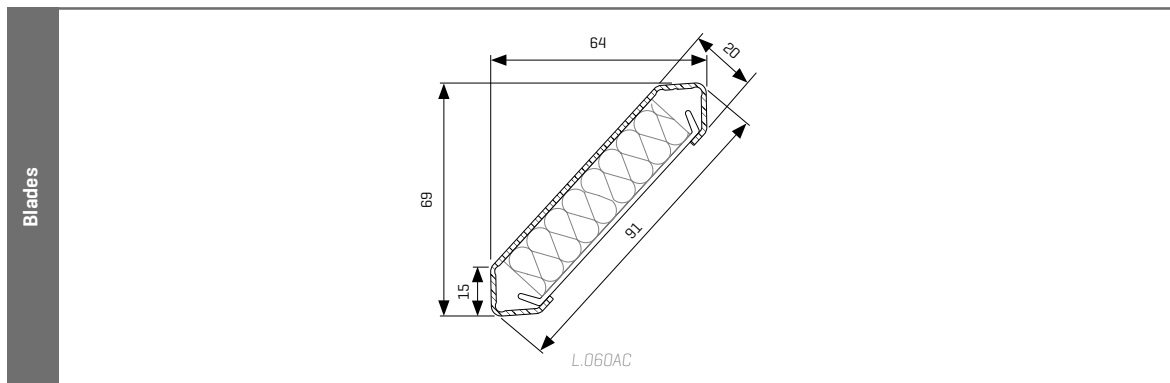

L.065





L.065AL

Rolled blades

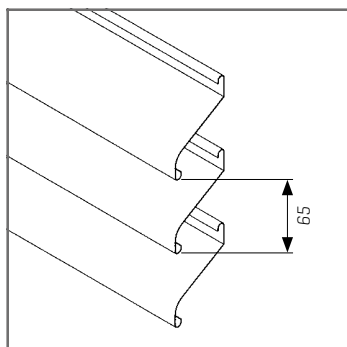

L.065

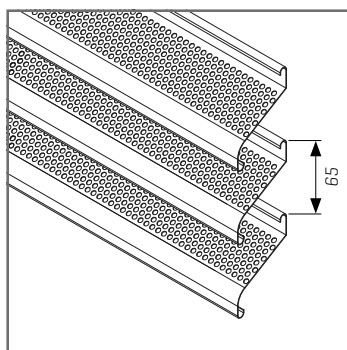

L.065AL.02

Rolled aluminium profile [L.065AL]; rolled aluminium profile, perforated [L.065AL.02]. Light duty strip material with a pitch of 65 mm and resistance to normal weather conditions. For use as a screen, ideal if a low-priced solution is required. Mounted with a soft flowing appearance [M1] or with front corner line [M2].

MATERIALS

- Aluminium EN AW 3005-H18

FINISH

Polyester powder coating RAL or Syntha Pulvin colours [60 - 80 µ/40 µ [UK]]

MESH

Fixed to rear of the support structure.

DOORS

Single and double doors available with standard RensonR hardware and rotating on pivot [see p. 106]

BLADE SUPPORT

- Type L.065AL
 - Single blade support type L.065AL.11 [width: 28 mm]
 - Double blade support type L.065AL.12 [width: 45 mm] [connecting piece for 2 blades]

TECHNICAL DATA

L.65AL	
Pitch	65 mm
Depth	50,0 mm
Height	70,0 mm
K-Factor*, supply	13,32
Visual free area*	70%
Physical free area*	56%
Max. unsupported span between two mullions**	1200 mm

* Definition see p. 6

** At q_p 800 Pa wind pressure

TECHNICAL DRAWINGS

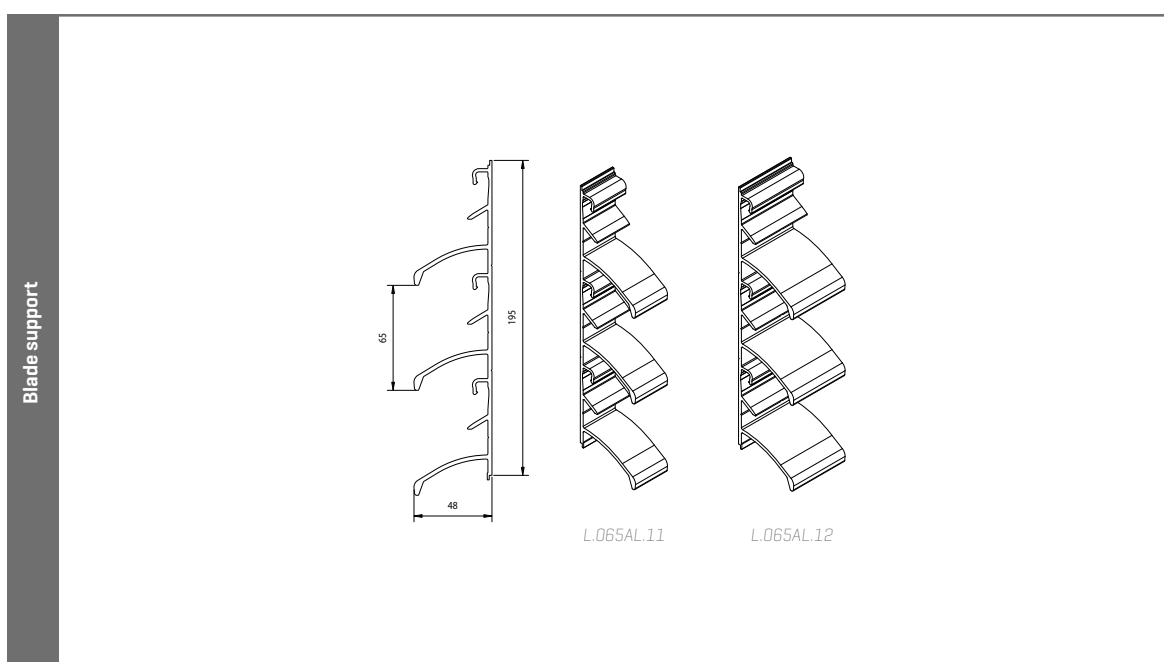
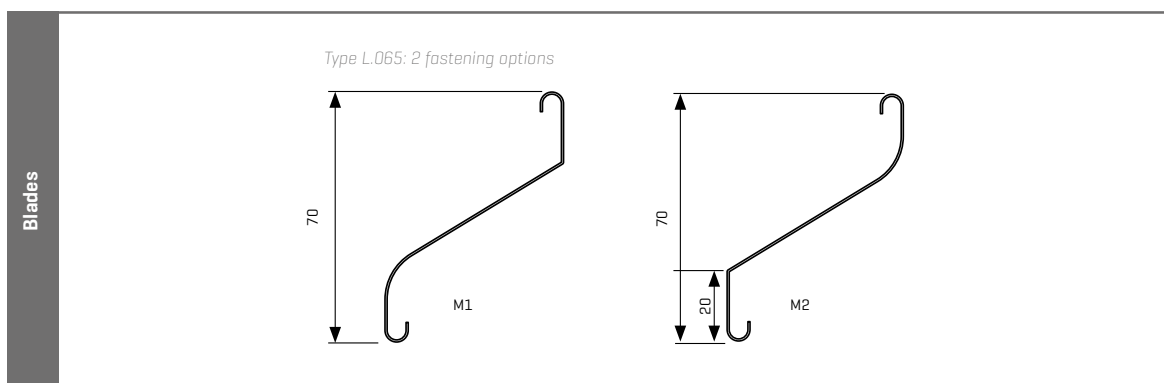

L.066



Linus® L.066.06



Linus® L.066.P



Linus® L.066.06



L.066.01 / L.066.06 / L.066S

Extruded aluminium blade

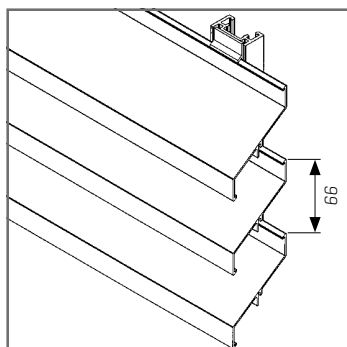

L.066.01

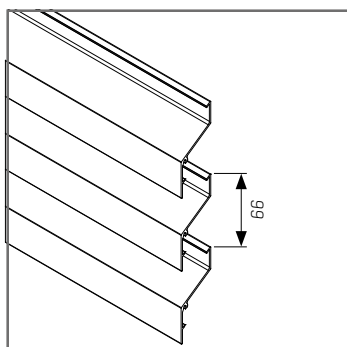

L.066.06

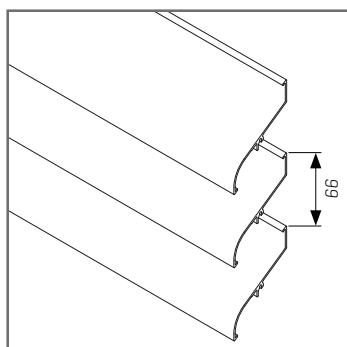

L.066S

L.066.01

Heavy-duty extruded aluminium profile at 66 mm pitch with high air flow. Variable 66 to 132 mm pitch is possible with blade supports of the type L.066.13 and L.066.14 (see drawing below). Blade L.066.02 available for nice top finish.

L.066.06

Extruded aluminium profile at 66 mm pitch, less deep version

L.066S

Extruded aluminium project profile with S-shaped [not in stock].

Variable steps between 66 to 132 mm are possible with blade holder types L.066.13 and L.066.14.

MATERIALS

Aluminium extrusion, alloy EN AW 6063 T66

FINISH

- Anodised [20 micron]
- Polyester powder coating RAL or Syntha Pulvin colours [60 - 80 µ/40 µ (UK)]

MESH

Fixed to rear of the support structure or in combination with blade L.066IM1.

DOORS

Single and double doors available with standard Renson® hardware and rotating on pivot [see p. 106].

BLADE SUPPORT

- Blade supports for 66 mm pitch
 - Single blade support: type L.066.11 (width 28 mm)
 - Double blade support for thermal expansion: type L.066.12 (width 34 mm) [connection piece for 2 blades]
- Blade supports for variable pitch 66 - 132 mm
 - Single blade support: type L.066.13 (width 28 mm)
 - Double blade support for thermal expansion: type L.066.14 (width 34 mm) [connecting piece for 2 blades]

TECHNICAL DATA

	L.066.01	L.066.06	L.066S
Pitch	66 mm	66 mm	66 mm
Depth	55,0 mm	31 mm	55,0 mm
Height	76,5 mm	73 mm	76,5 mm
K-Factor*, supply	14,24	29,11	13,62
Visual free area*	70%	50%	70%
Physical free area*	49,2%	38%	49%
Max. unsupported span between two mullions**	1600 mm	1500 mm	1600 mm

* Definition see p. 6

** At q_p 800 Pa wind pressure

TECHNICAL DRAWINGS

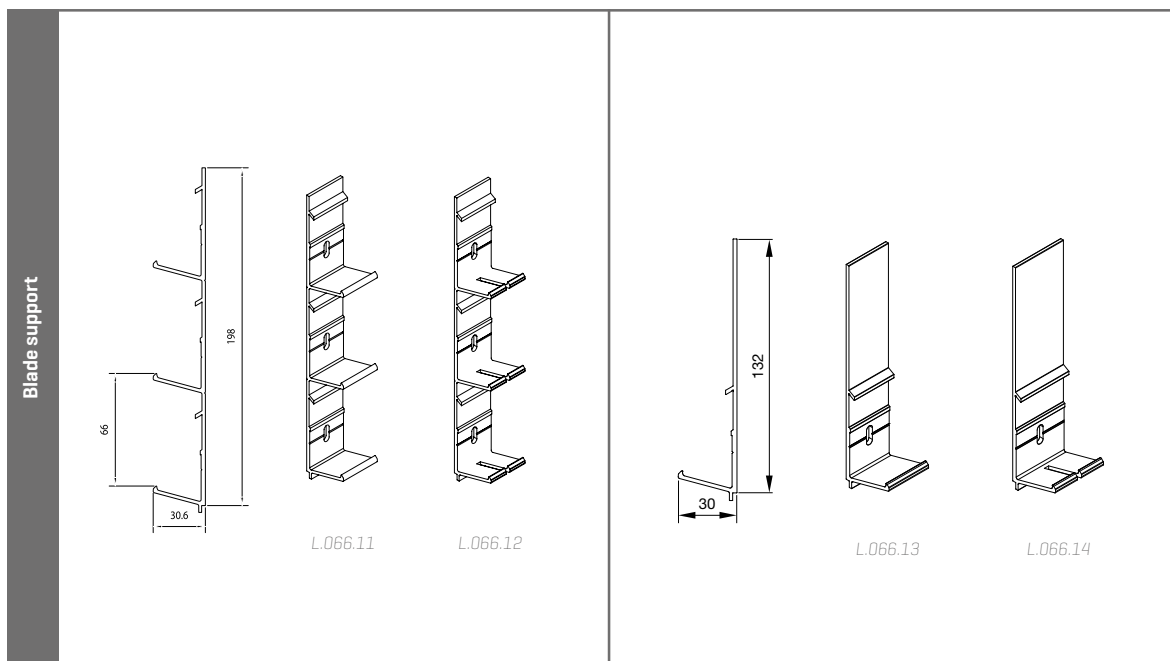
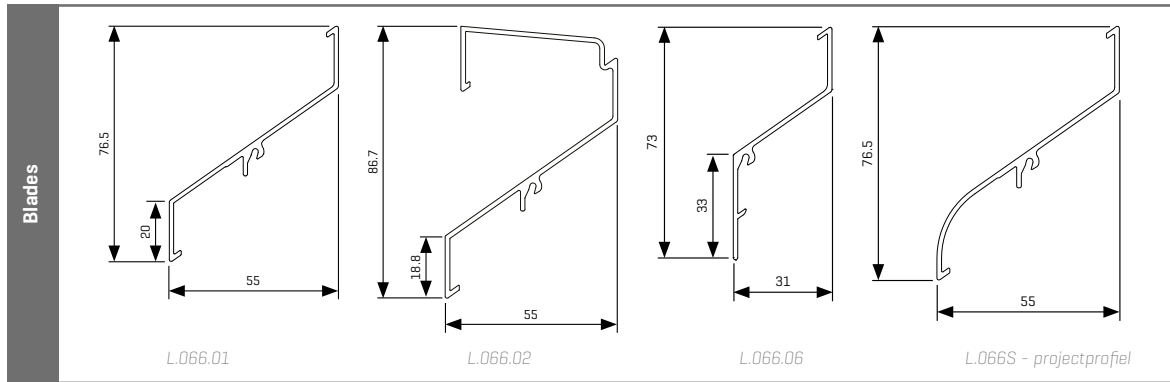

L.066CL / L.066IM1

Extruded aluminium blade

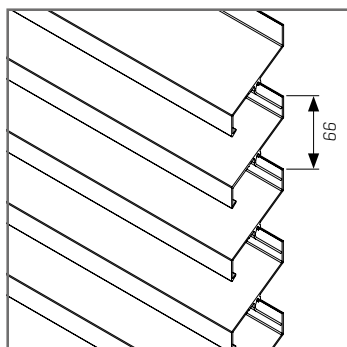

L.066CL

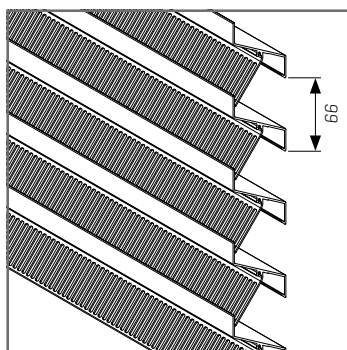

L.066IM1

Installation
up to **2x**
faster

L.066CL

Suitable for fully or partially closed continuous louvre systems.

L.066IM1

Extruded aluminium profile with integrated insect mesh. This 66 mm pitch blade clipped into the standard blade support combines weather resistance and insect protection. No separate insect mesh is needed, resulting in considerable time savings during installation. This blade is also the ideal solution for applications where installation of a separate insect mesh is difficult. The L.066IM1 blade combines perfectly with the standard L.066.01 blade and L.066CL closed blade.

MATERIALS

Aluminium extrusion, alloy EN AW 6063 T66.

FINISH

- Anodised [20 micron]
- Polyester powder coating RAL or Syntha Pulvin colours [60 - 80 µ/40 µ [UK]]

DOORS

Single and double doors available with standard Renson® hardware and rotating on pivot [see p. 106]

BLADE SUPPORT

- Single blade support: type L.066.11 [width: 28 mm]
- Double blade support for thermal expansion:
L.066.12 [width: 34 mm] [connecting piece for 2 blades]

TECHNICAL DATA

	L.066CL	L.066IM1
Pitch	66 mm	66 mm
Depth	55 mm	55 mm
Height	76,5 mm	76,5 mm
K-Factor*, supply		16,66
Visual free area*		70 %
Physical free area*		32 %
Max. unsupported span between two mullions**	2300 mm	2300 mm

* Definition see p. 6

** At q_p 800 Pa wind pressure

TECHNICAL DRAWINGS

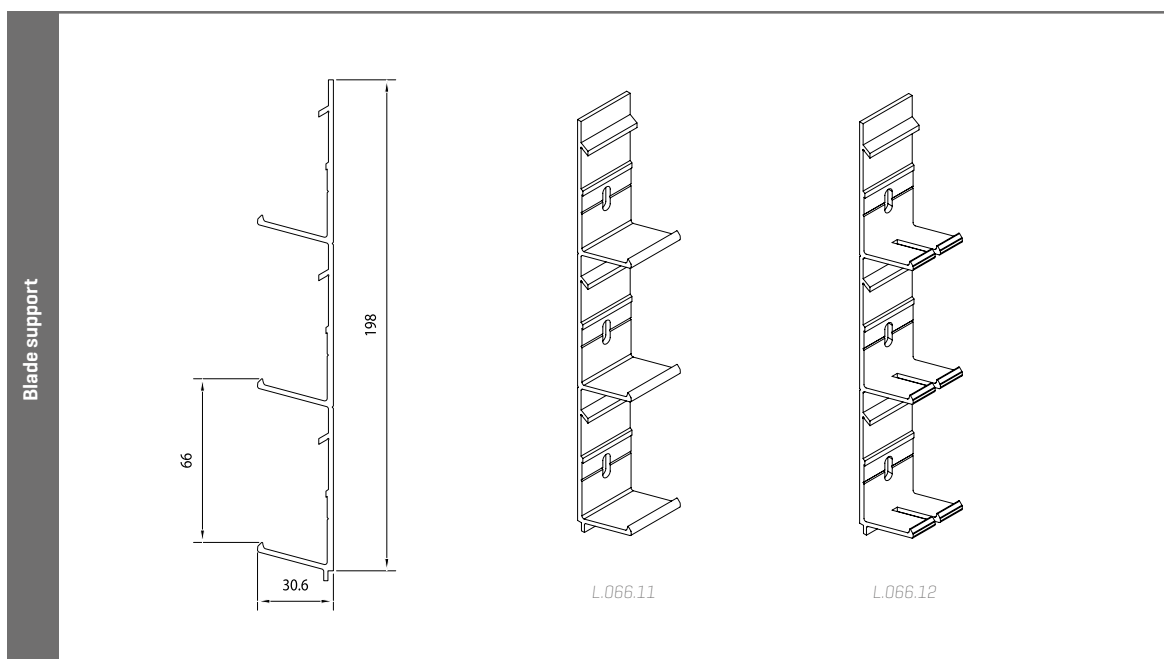
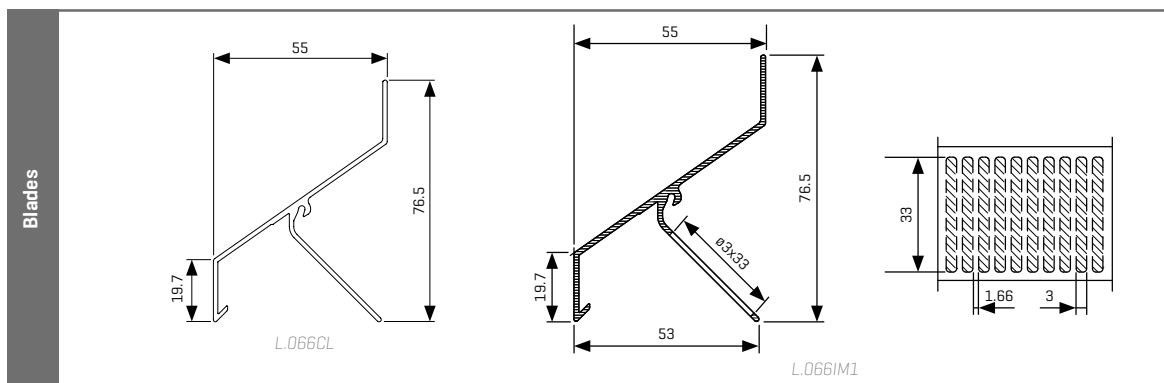

L.066V

Extruded aluminium blade

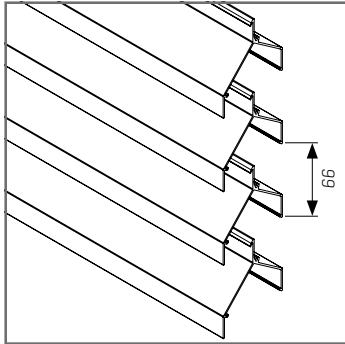

L.066V

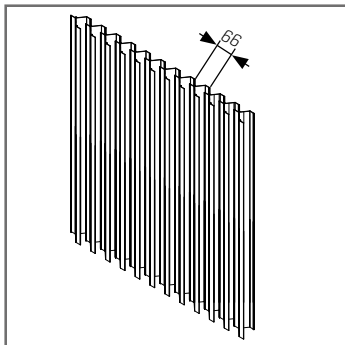

L.066V - vertical blades

Extruded aluminium V-shape profile with a 66 mm pitch. For applications requiring restricted access, such as in high voltage units, or visual screen and high water-resistance. If a continuous louvre wall with high water-tightness properties is required, the blade is installed vertically to achieve class A water resistance at 1.5 m/s. Blade L.066V can be combined with blade L.066 thanks to their identical appearance.

MATERIALS

Aluminium extrusion, alloy EN AW 6063 T66

FINISH

- Anodised [20 micron]
- Polyester powder coating RAL or Syntha Pulvin colours [60 - 80 µ/40 µ [UK]]

MESH

Fixed to rear of the support structure.

DOORS

Single and double doors available with standard Renson® hardware and rotating on pivot [see p. 106]

BLADE SUPPORT

- Single blade support: type L.066.11 [width: 28 mm]
 - Double blade support for thermal expansion: L.066.12 [width: 34 mm] [connecting piece for 2 blades]
 - The blade supports are the same for all L.066 blade types. They are only fitted upside down for blade type L.066V.

TECHNICAL DATA

L.066V	
Pitch	66 mm
Depth	61,5 mm
Height	74 mm
K-Factor*, supply	66,10
K-Factor*, extraction	79,72
Visual free area*	70%
Physical free area*	40,6%
Max. unsupported span between two mullions**	1650 mm

* Definition see p. 6

** At q_p 800 Pa wind pressure

TECHNICAL DRAWINGS

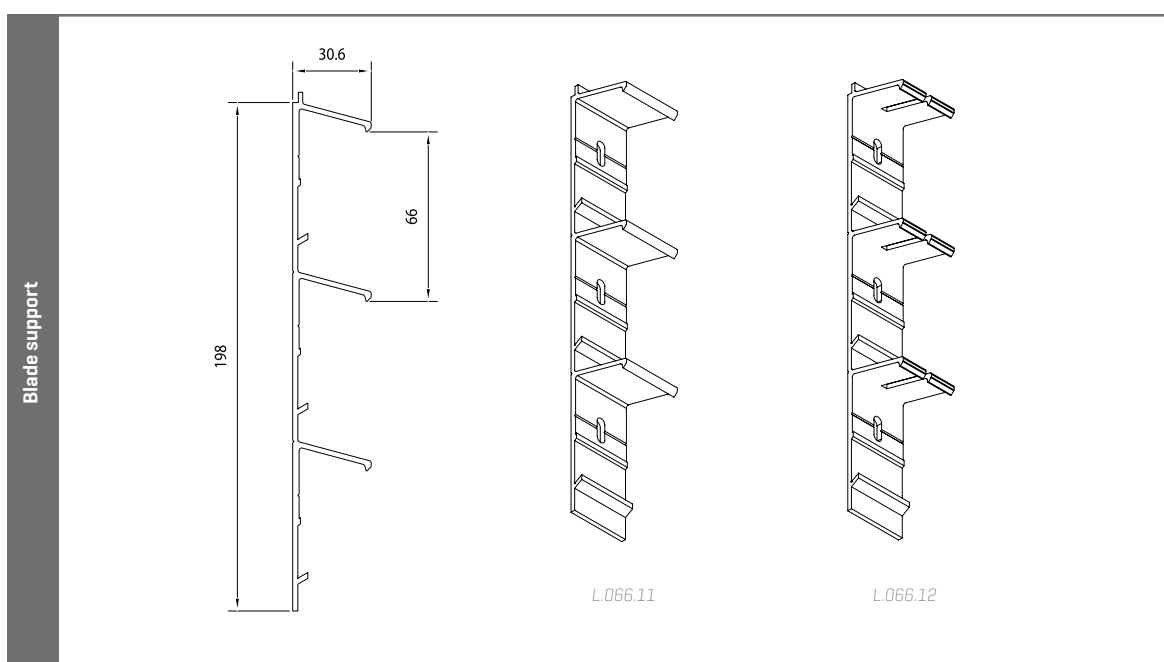
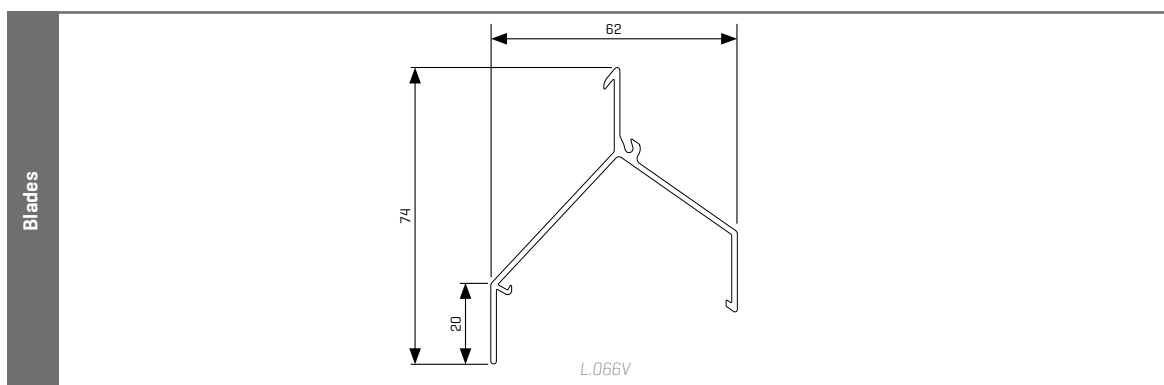

L.066P

Extruded aluminium blade

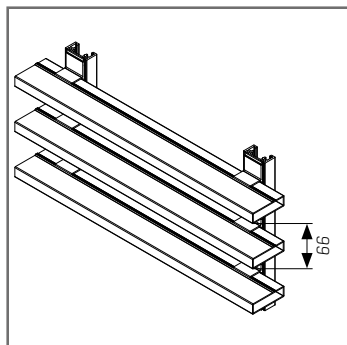

L.066P



The Linius L.066P Plano type is characterised by its unique and contemporary design. Linius Plano blades are rectangular extruded aluminium blades. The system can be used for different purposes. It offers the opportunity to create modern architectural constructions in a simple way, both outside and inside.

In order to guarantee an aesthetical look, both blade ends can be provided with a pvc end cap.

MATERIALS

Aluminium extrusion, alloy EN AW 6063 T66

FINISH

- Anodised [20 micron]
- Polyester powder coating RAL or Syntha Pulvin colours [60 - 80 µ/40 µ [UK]]

END CAP

End cap L.066P.13 in black or grey PVC

BLADE SUPPORT

- Single blade support: L.066P.11 [width: 28 mm]
- Double blade support for thermal expansion:
L.066P.12 [width: 34 mm] [connecting piece for 2 blades]

APPLICATIONS

- Sunshading blades
- Visual screen
- Aesthetic cladding
- Both exterior and interior applications
- Room divider
- Ceiling covering

TECHNICAL DATA

L.066P	
Pitch	66 mm
Depth	53 mm
Height	15 mm
K-Factor*, supply	3,57
Visual free area*	77 %
Physical free area*	77 %
Max. unsupported span between two mullions**	800 mm

* Definition see p. 6

** At q_p 800 Pa wind pressure

TECHNICAL DRAWINGS

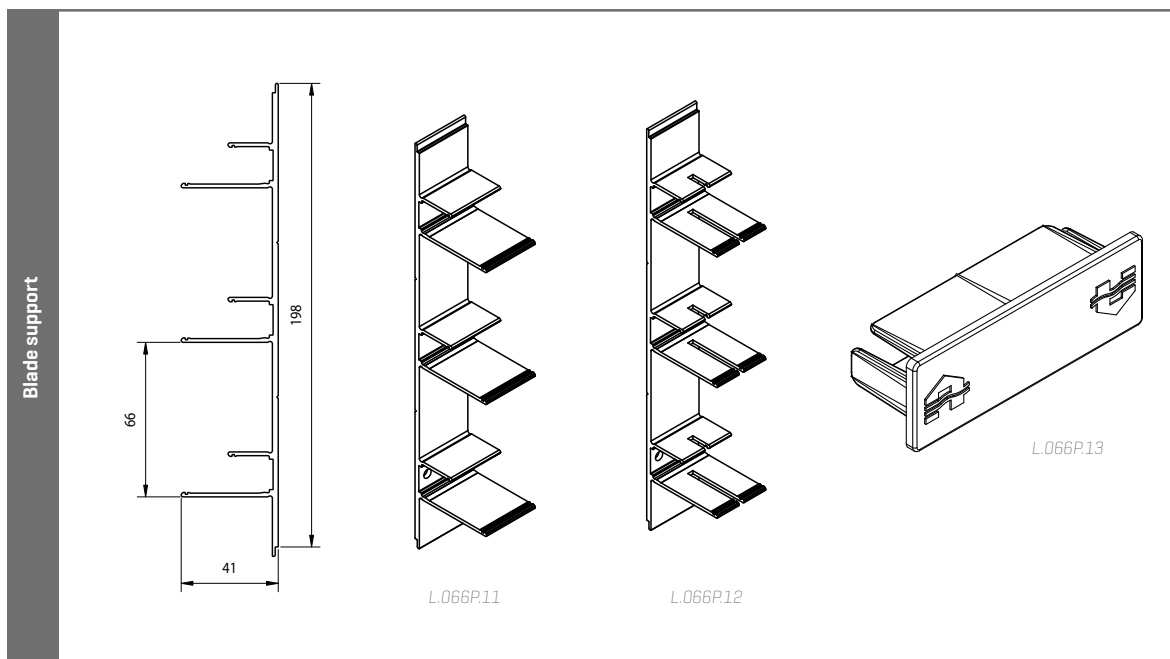
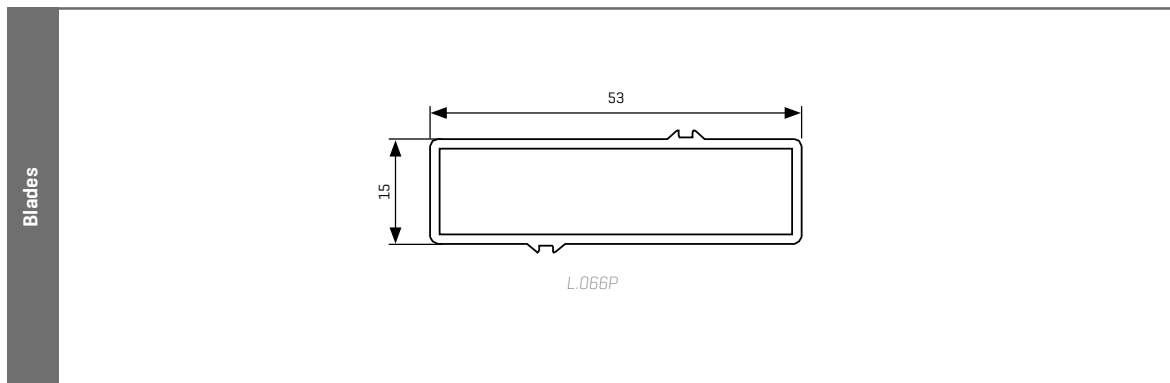

L.075





PRODUCTS

L.075 / **BLADE TYPES**

L.075W

Extruded aluminium blade

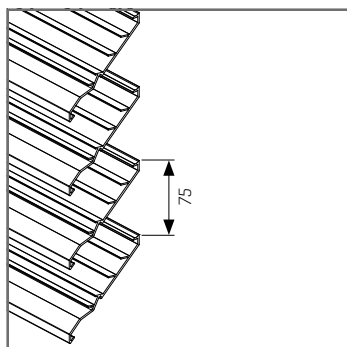

L.075W



The new weaterable blade L.075W is tested according to EN13030:2001, BSRIA certificate available. With class A2 at a wind speed of 13 m/second and a suction air velocity of 0 m/s, this blade is particularly appropriate for air discharge applications requiring water resistance. Blades with a pitch of 75 mm, for simple and invisible assembly by clipping the blades into het blade supports included in the system.

MATERIALS

Aluminium extrusion, alloy EN AW 6063 T66

FINISH

- Anodised [20 micron]
- Polyester powder coating RAL or Syntha Pulvin colours [60 - 80 µ/40 µ (UK)]

MESH

Fixed to rear of the support structure.

BLADE SUPPORTS L.075W

- Single blade support: type L.075W.11
- Double blade support for thermal expansion: type L.075W.12

TECHNICAL DATA

	L.075W
Pitch	75 mm
Depth	77 mm
Height	101 mm
Watertightness***	A2 [0 m/s]
Physical free area	53 %
K-Factor*, supply	10,89
C _q -coefficient	0,303
C _d -coefficient	0,310
Max. unsupported span between two mullions**	1473 mm

* Definition see p. 6

** At q_p 800 Pa wind pressure

*** With mesh 2,3 x 2,3 mm

TECHNICAL DRAWINGS

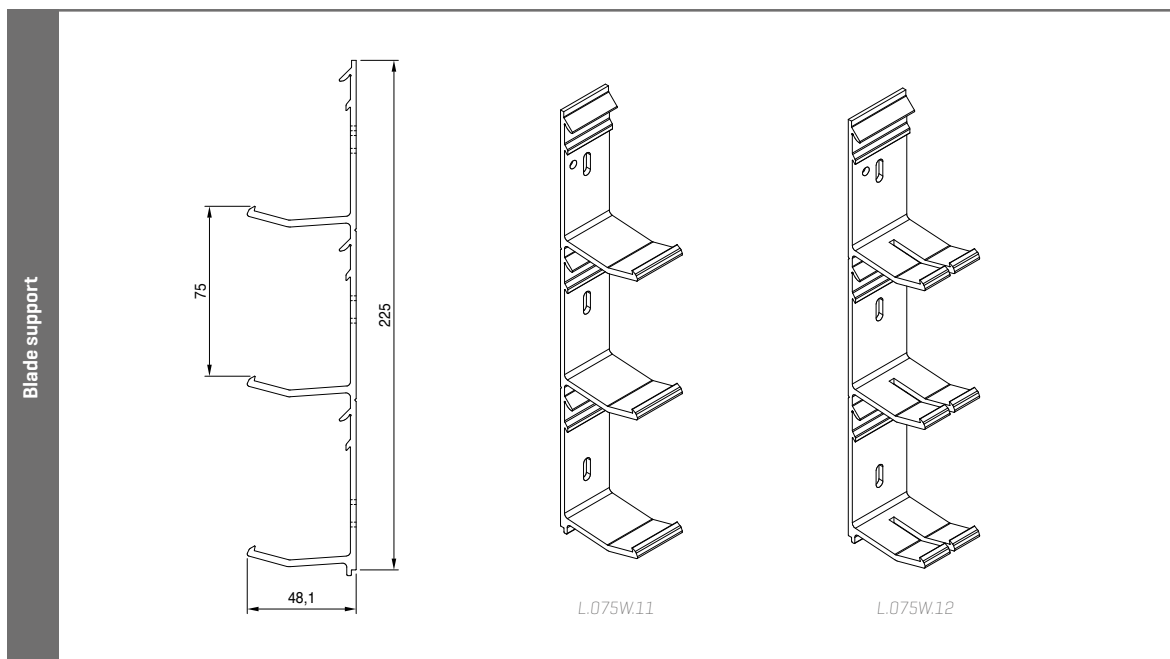
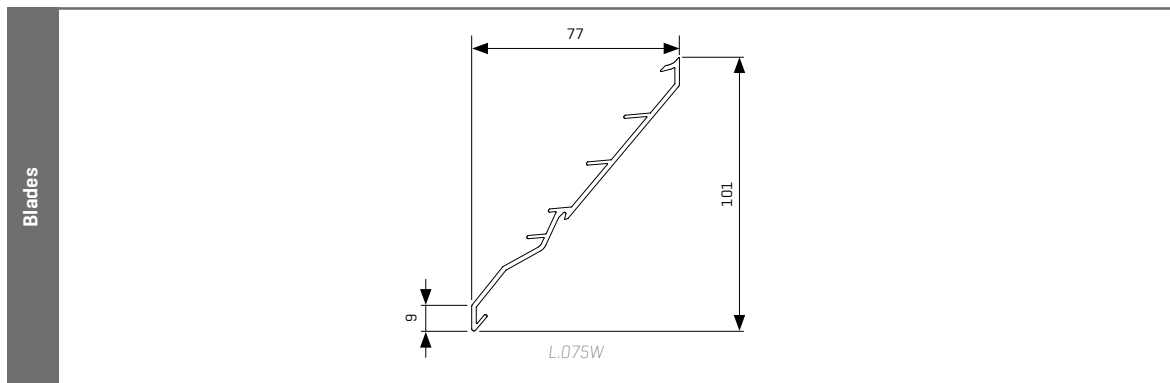

L.075HF

Extruded aluminium blade

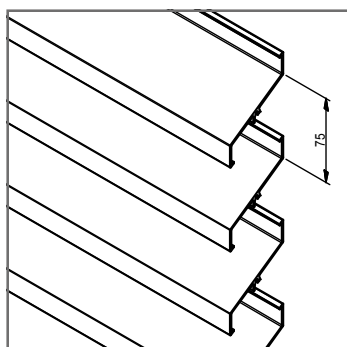

Extruded aluminium profile with minimal resistance to airflow. Suited for applications where large air flow and large water resistance is required. Recommended solution for air discharge.

MATERIALS

Aluminium extrusion, alloy EN AW 6063 T66

FINISH

- Anodised [20 micron]
- Polyester powder coating RAL or Syntha Pulvin colours (60 - 80 µ/40 µ [UK])

MESH

Fixed to rear of the support structure or in combination with blade L.066IM1.

DOORS

Single and double doors available with standard Renson® hardware and rotating on pivot [see p. 106].

BLADE SUPPORT

Blade supports for 75 mm pitch

TECHNICAL DATA

L.075HF	
Pitch	75 mm
Depth	55 mm
Height	76,5 mm
Physical free area	52 %
K-Factor*, supply	13,13
C _e -coefficient	0,276
C _d -coefficient	0.265
Max. unsupported span between two mullions**	1600 mm

* Definition see p. 6

** At q_s 800 Pa wind pressure

*** With mesh 6 x 6 mm

TECHNICAL DRAWINGS

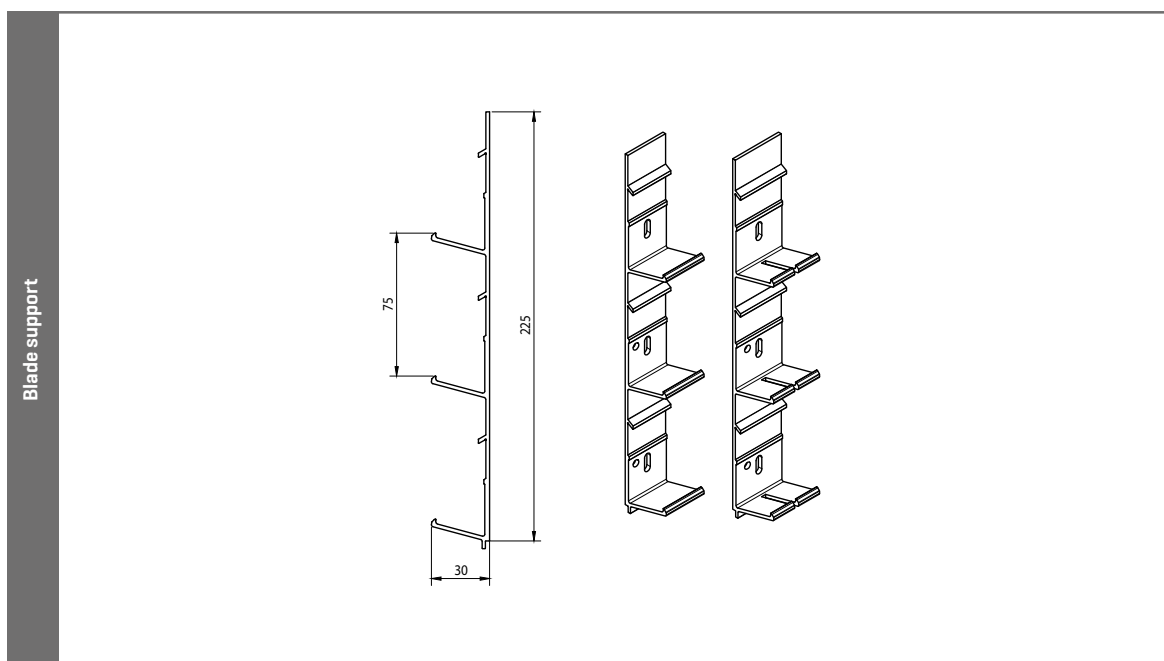
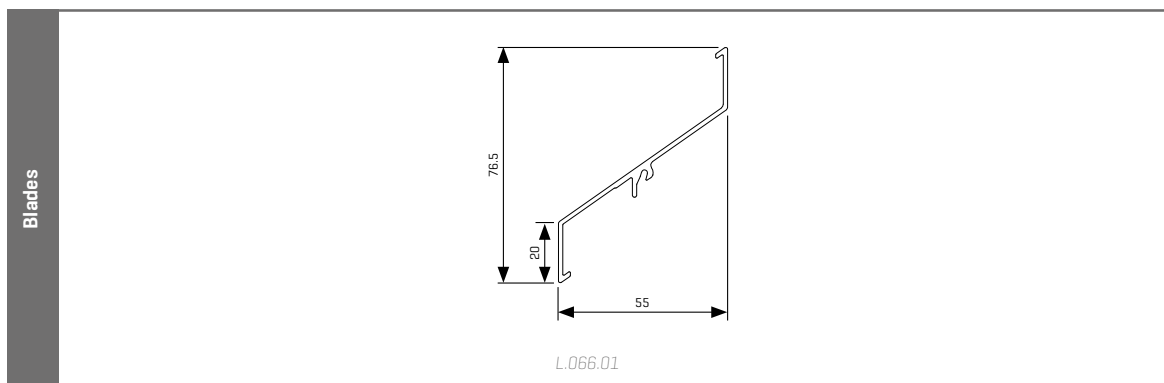

L.095



Linus® L.095.01



64

Linus® L.095.01





L.095.01 / L.095S

Extruded aluminium blade

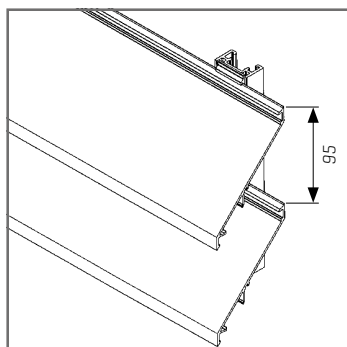

L.095.01

L.095.01

Extra heavy-duty extruded aluminium blade with high free airflow and a pitch of 95 mm.

L.095S

Extruded aluminium project profile with S-shaped, front side [not in stock].

MATERIALS

Aluminium extrusion, alloy EN AW 6063 T66

FINISH

- Anodised [20 micron]
- Polyester powder coating RAL or Syntha Pulvin colours [60 - 80 µ/40 µ [UK]]

MESH

Clicked between the blades [see p. 100], or fixed to the rear of the support structure.

DOORS

Single and double doors available with standard Renson® hardware and rotating on pivot [see p. 106]

BLADE SUPPORT

- Single blade support: type L.095.11 [width: 28 mm]
- Double blade support for thermal expansion:
L.095.12 [width: 34 mm] [connecting piece for 2 blades]

TECHNICAL DATA

	L.095.01	L.095S
Pitch	95 mm	95 mm
Depth	77,2 mm	77,2 mm
Height	102,1 mm	101,1 mm
K-Factor*, supply	12,40	9,70
Visual free area*	86%	55%
Physical free area*	55,5%	1450 mm
Max. unsupported span between two mullions**	1300 mm	

* Definition see p. 6

** At q_p 800 Pa wind pressure

TECHNICAL DRAWINGS

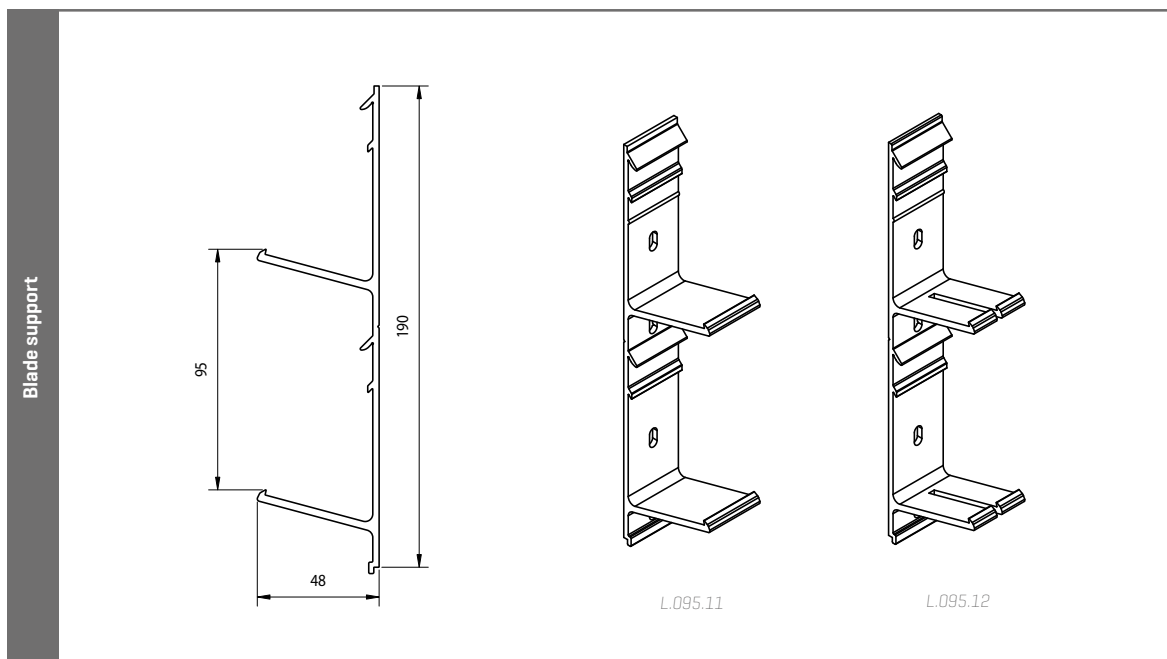
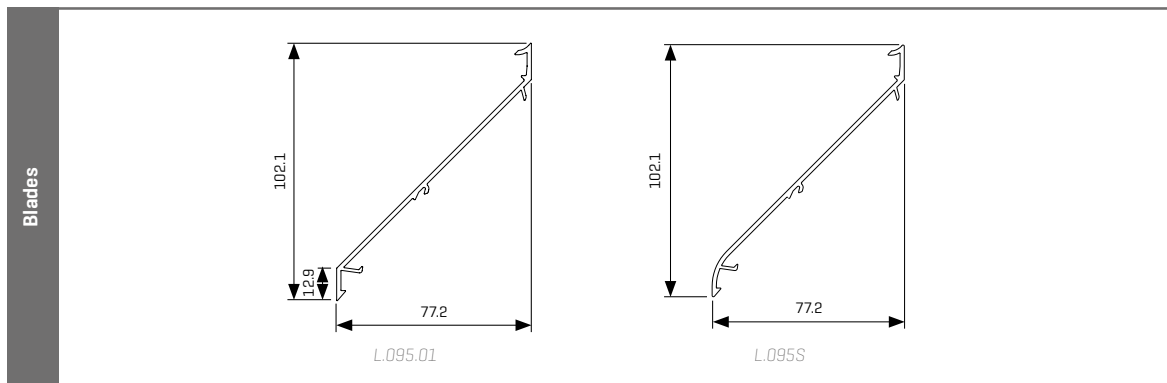

L.120

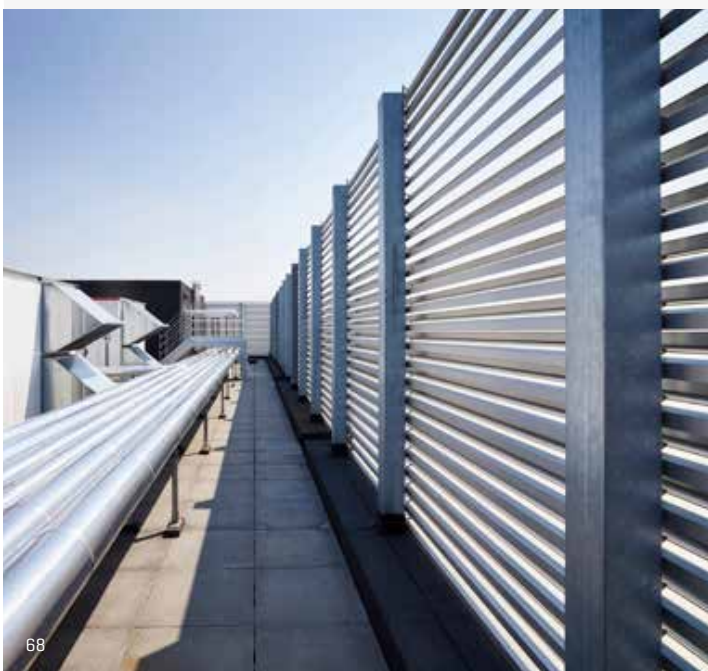



L.120.01

Extruded aluminium blade

Installation
up to **2x**
faster

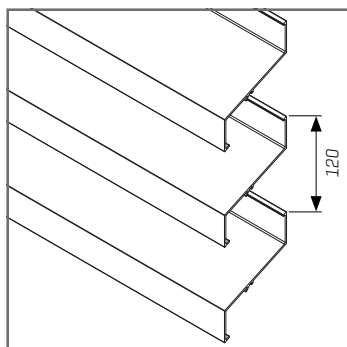

L.120.01



Extruded aluminium profile for large spans at 120 mm pitch with an optimal air flow. Improved installation speed thanks to a small number of clips and blades.

MATERIALS

Aluminium extrusion, alloy EN AW 6063 T66

FINISH

- Anodised [20 micron]
- Polyester powder coating RAL or Syntha Pulvin colours (60 - 80 µ/40 µ [UK])

MESH

Fixed to rear of the support structure.

DOORS

Single and double doors available with standard Renson® hardware and rotating on pivot [see p. 106]

BLADE SUPPORT

- Single blade support: Type L.120.11 (width: 28 mm)
- Double blade support for thermal expansion:
L.120.12 (width: 34 mm) [connecting piece for 2 blades]
- Blade supports for variable pitches 120-240 mm
 - Single blade support: type L.120.13 (width 28 mm)
 - Double blade support for thermal expansion:
type L.120.14 (width 34 mm) [connecting piece for 2 blades]

TECHNICAL DATA

L.120.01	
Pitch	120 mm
Depth	90 mm
Height	120 mm
K-Factor*, supply	13,82
K-Factor*, extraction	14,68
Visual free area*	66%
Physical free area*	60%
Max. unsupported span between two mullions**	2300 mm

* Definition see p. 6

** At q_p 800 Pa wind pressure



TECHNICAL DRAWINGS

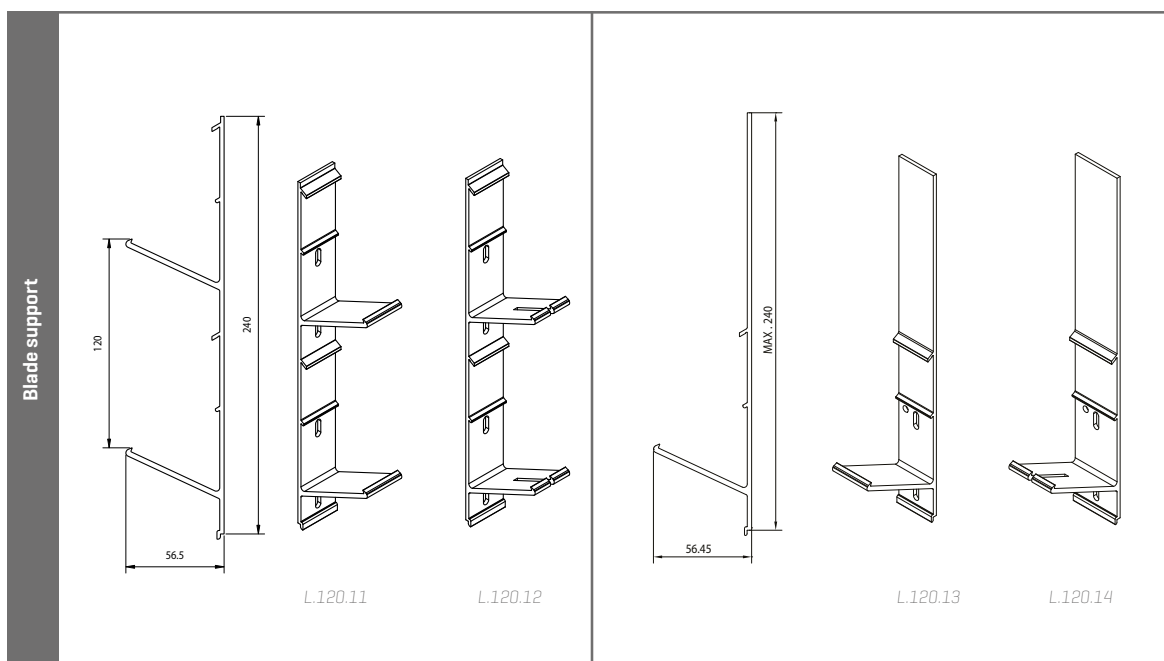
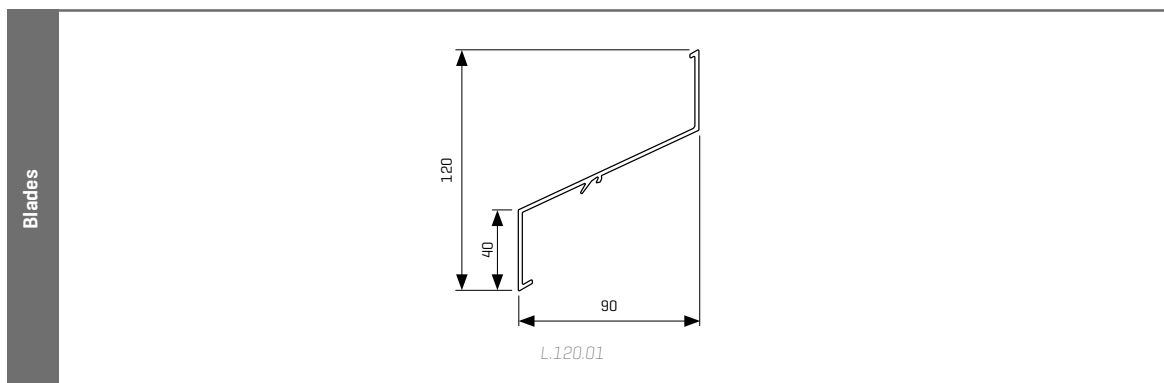

L.150





L.150ACS / L.150ACL

Extruded aluminium blade

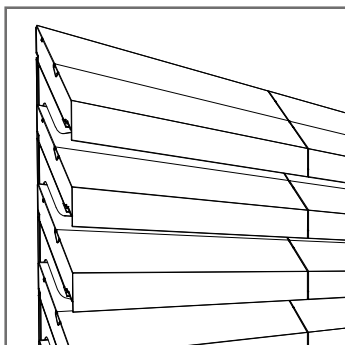

L.150ACS

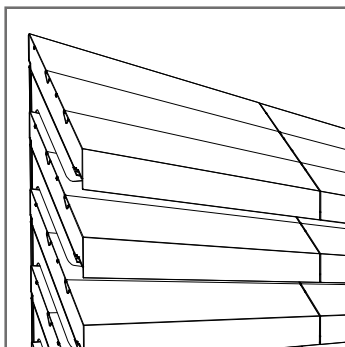

L.150ACL

Extruded aluminium profile with a pitch of 150 mm and perforated underside; maximum blade length of 6,000 mm. Blades packed with inorganic mineral wool for acoustic performance. Developed to provide an aesthetic solution for noise reducing continuous louvre applications.

In order to guarantee an aesthetic look and extra protection of the mineral wool, the blade can be provided with lasered aluminium end caps.

MATERIALS

L.150ACS and L.150ACL : extruded aluminium, EN AW - 6063 T66, perforated aluminium sheet.

FINISH

- Anodised [20 micron]
- Polyester powder coating RAL or Syntha Pulvin colours [60 - 80 µ/40 µ [UK]]
- Perforated plate at the back side painted in black [MAT 9005]

MESH

Fixed to rear of the support structure.

DOORS

Single and double doors available with standard Renson® hardware and rotating on pivot [see p. 106]

END CAP

Lasered aluminium end caps in the same colour of the blade.

- L.150.ACS.13 : for blade L.150ACS.01
- L.150.ACL.13 : for blade L.150ACL.01
- L.150.ACL.14 : for blade L.150ACL with angle cuts at 45°

ACOUSTIC PROPERTIES

- L.150ACS: $R_w [C;Ctr] = 11 [-1;-2]$ dB
- L.150ACL: $R_w [C;C_p] = 15 [-1;-4]$ dB

BLADE SUPPORT

- L.150ACS: type L.150ACS.11
- L.150ACL: type L.150ACL.11

TECHNICAL DATA

	L.150ACS	L.150ACL
Pitch	150 mm	150 mm
Depth	147 mm	222 mm
Height	239 mm	328 mm
K-Factor*, supply	38,58	37,3
Visual free area*	54%	54%
Physical free area*	34,3%	34,3%
Max. unsupported span between two mullions**	2800 mm	2700 mm

* Definition see p. 6

** At q_p 800 Pa wind pressure

TECHNICAL DRAWINGS

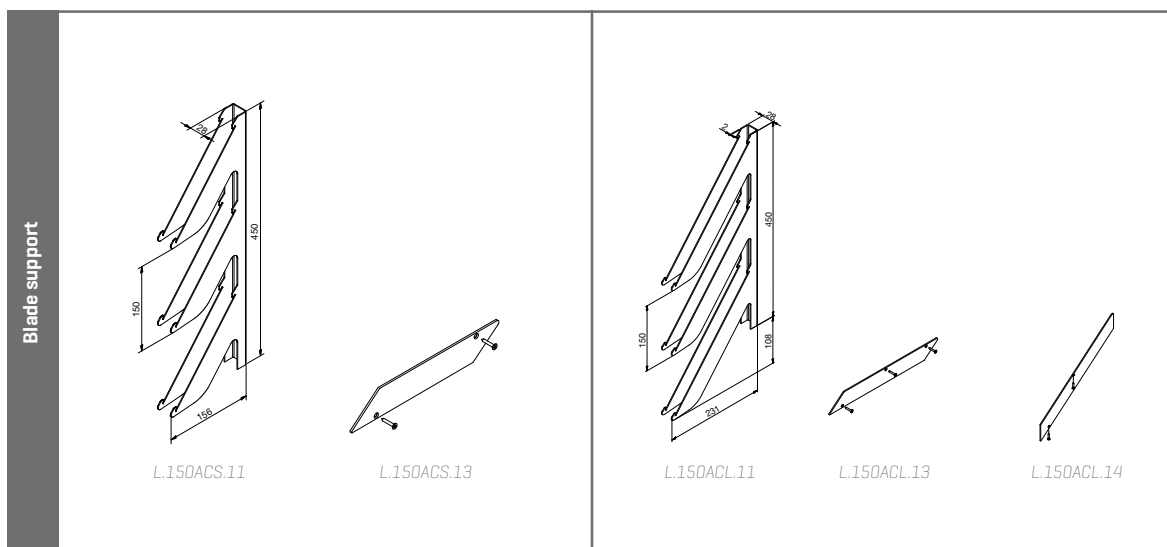
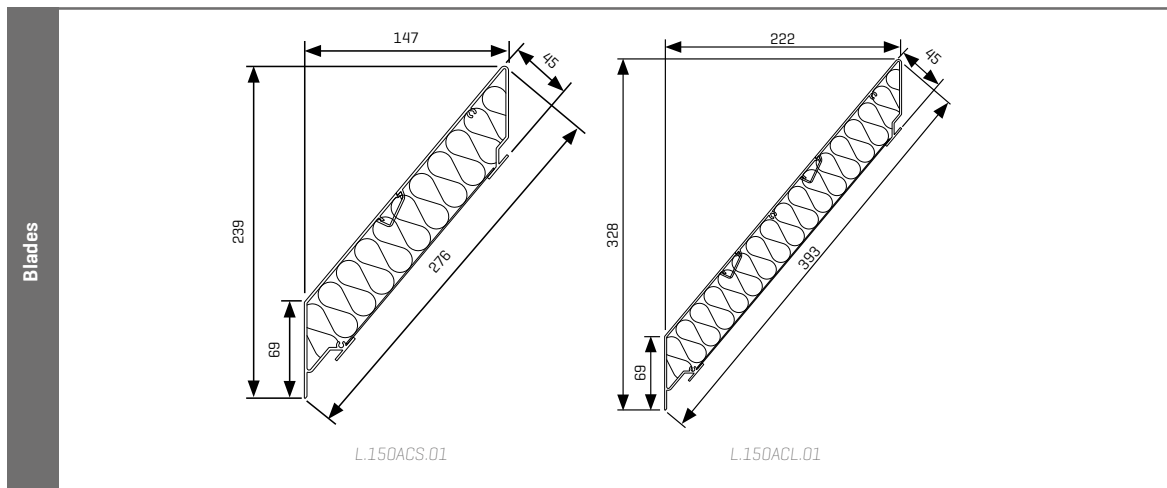

L.150DAC

Extruded aluminium blade

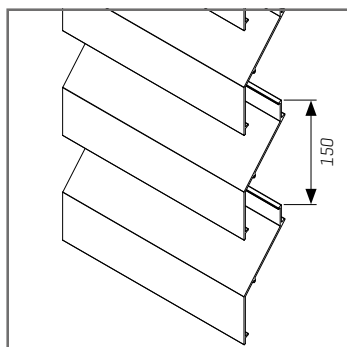

L.150DAC



L.150ACS.01
L.150ACL.01

L.150DAC.01

Extruded aluminum profile with a step of 150 mm, according acoustic system ^(*). This can be perfectly combined with the acoustic blades L.150ACS.01 / L.150ACL.01, on places in the wall where no acoustic damping is required.

MATERIALS

- Extruded aluminium, EN AW - 6063 T66

FINISH

- Anodised [20 micron]
- Polyester powder coating RAL or Syntha Pulvin colours [60 - 80 µ/40 µ (UK)]

BLADE SUPPORT

- Single blade support: type L.150.11 or L.170.11 ^(*)
- Double blade support for thermal expansion: type L.150.12 or L.170.12 ^(*)

^(*) pitch of the blade according to system L.150DAC

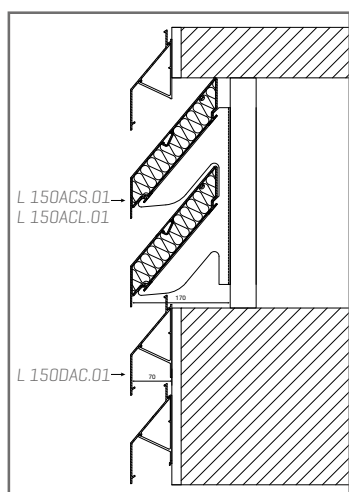

L.150ACS.01
L.150ACL.01

L.150DAC.01

TECHNICAL DATA

L.150DAC	
Pitch	150 mm
Depth	70 mm
Height	170 mm
K-Factor, supply	47,7
K-Factor*, extraction	42,47
Physical free area*	34%
Max. unsupported span between two mullions**	ca 2400 mm

* Definition see p. 6

** At q_p 800 Pa wind pressure



TECHNICAL DRAWINGS

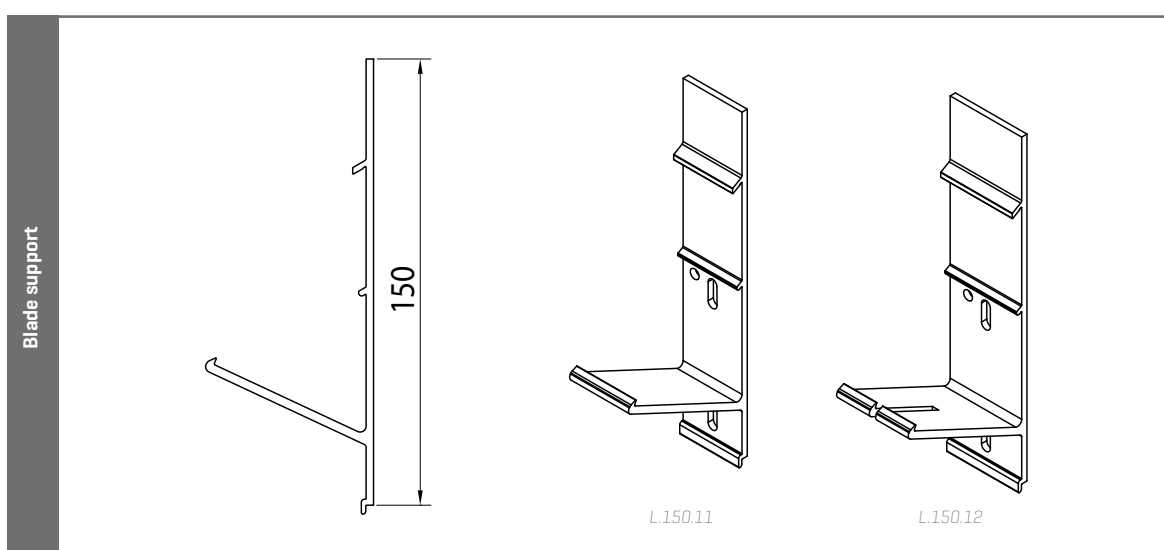
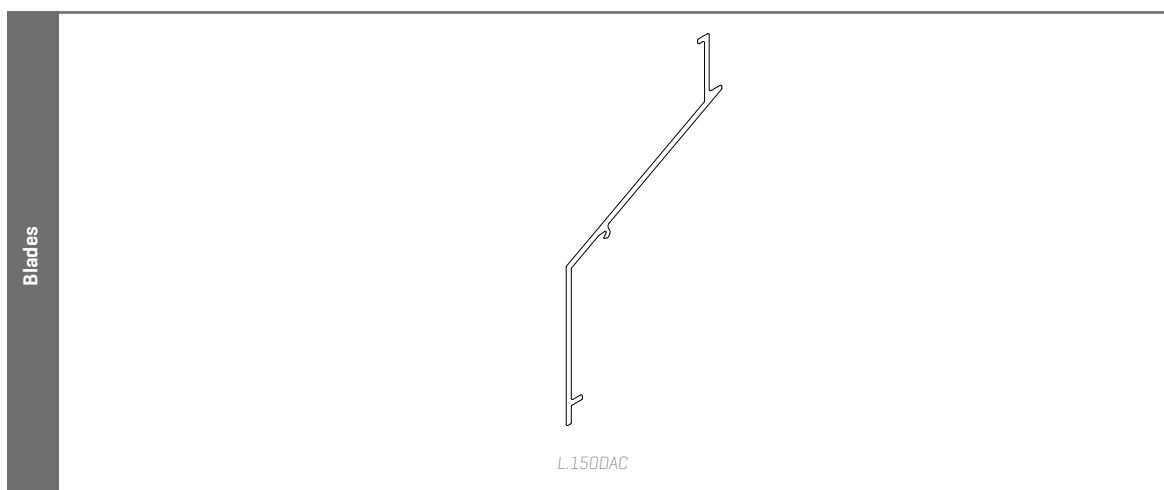

L.170





L.170ACS / L.170ACL

Extruded aluminium blade

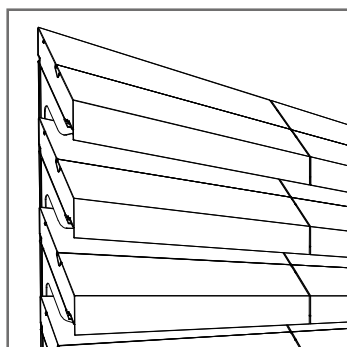

L.170ACS

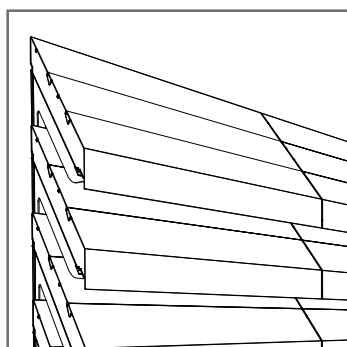

L.170ACL

Extruded aluminium profile with a pitch of 170 mm and perforated underside; maximum blade length of 6,000 mm. Blades packed with inorganic mineral wool for acoustic performance. Developed to provide an aesthetic solution for noise reducing continuous louvre applications.

In order to guarantee an aesthetic look and extra protection of the mineral wool, the blade can be provided with lasered aluminium end caps.

MATERIALS

Aluminium extrusion, alloy EN AW 6063 T66

FINISH

- Anodised [20 micron]
- Polyester powder coating RAL or Syntha Pulvin colours [60 - 80 µ/40 µ [UK]]
- Perforated plate at the back side painted in black [MAT.9005]

MESH

Fixed to rear of the support structure.

DOORS

Single and double doors available with standard Renson® hardware and rotating on pivot [see p. 106]

END CAP

Lasered aluminium end caps in the same colour of the blade.

- L.150.ACS.13 : for blade L.150ACS.01
- L.150.ACL.13 : for blade L.150ACL.01
- L.150.ACL.14 : for blade L.150ACL with angle cuts at 45°

ACOUSTIC PROPERTIES

- L.170ACS: $R_w [C;Ctr] = 9 [0;-1]$ dB
- L.170ACL: $R_w [C;Ctr] = 13 [-1;-3]$ dB

BLADE SUPPORT

- L.170ACS: type L.170ACS.11
- L.170ACL: type L.170ACL.11

TECHNICAL DATA

	L.170ACS	L.170ACL
Pitch	170 mm	170 mm
Depth	147 mm	222 mm
Height	239 mm	328 mm
K-Factor*, supply	25,4	28,58
Visual free area*	59%	59%
Physical free area*	37%	37%
Max. unsupported span between two mullions**	2800 mm	2700 mm

* Definition see p. 6

** At q_p 800 Pa wind pressure

TECHNICAL DRAWINGS

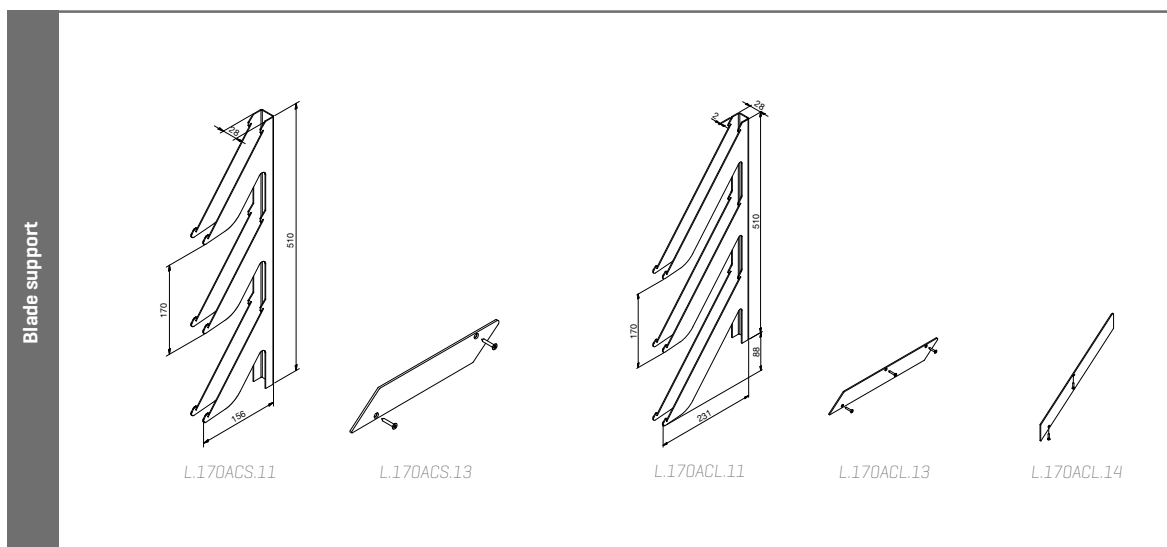
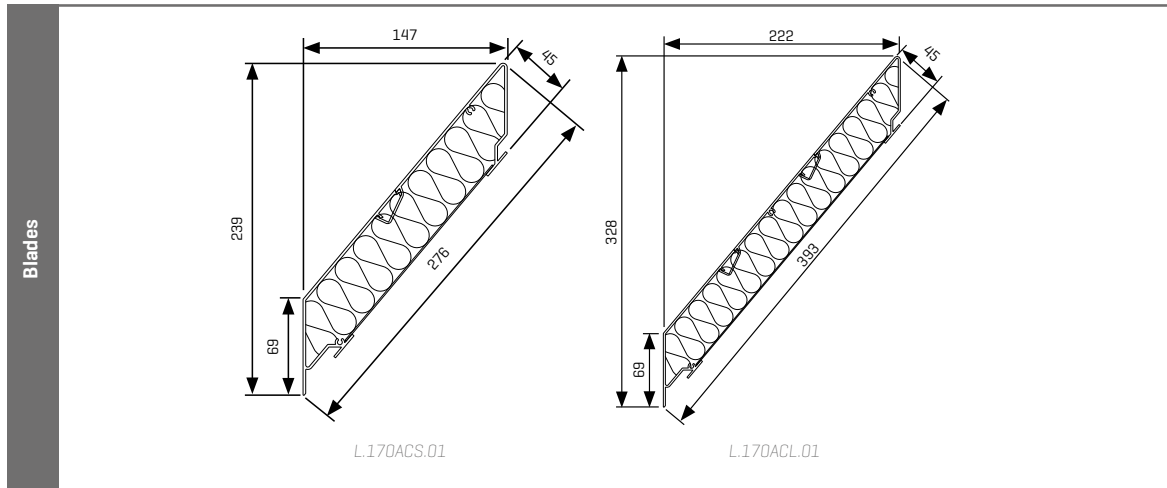

L.170DAC

Extruded aluminium blade

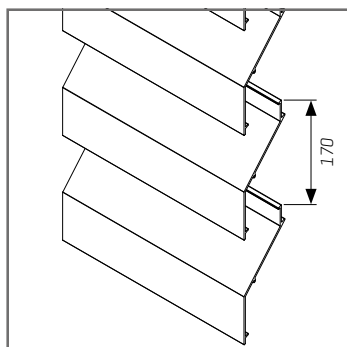

Extruded aluminum profile with a step of 170 mm, according acoustic system ^(*). This can be perfectly combined with the acoustic blades L.150ACS.01 / L.150ACL.01, on places in the wall where no acoustic damping is required.

MATERIALS

Aluminium extrusion, alloy EN AW 6063 T66

FINISH

- Anodised [20 micron]
- Polyester powder coating RAL or Syntha Pulvin colours (60 - 80 µ/40 µ [UK])

BLADE SUPPORT

- Single blade support: type L.150.11 or L.170.11 ^(*)
- Double blade support for thermal expansion: type L.150.12 or L.170.12 ^(*)

^(*) pitch of the blade according to system L.170DAC

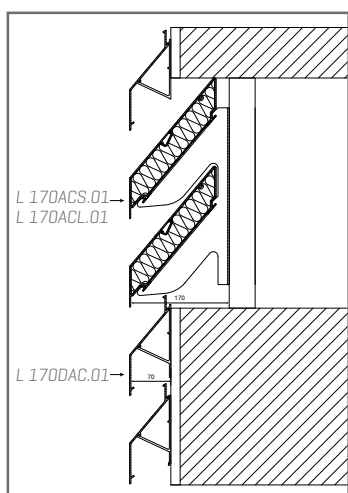

TECHNICAL DATA

L.170DAC	
Pitch	170 mm
Depth	70 mm
Height	170 mm
K-Factor, supply	41,08
K-Factor*, extraction	37,58
Physical free area*	37%
Max. unsupported span between two mullions**	ca 2400 mm

* Definition see p. 6

** At q_p 800 Pa wind pressure

TECHNICAL DRAWINGS

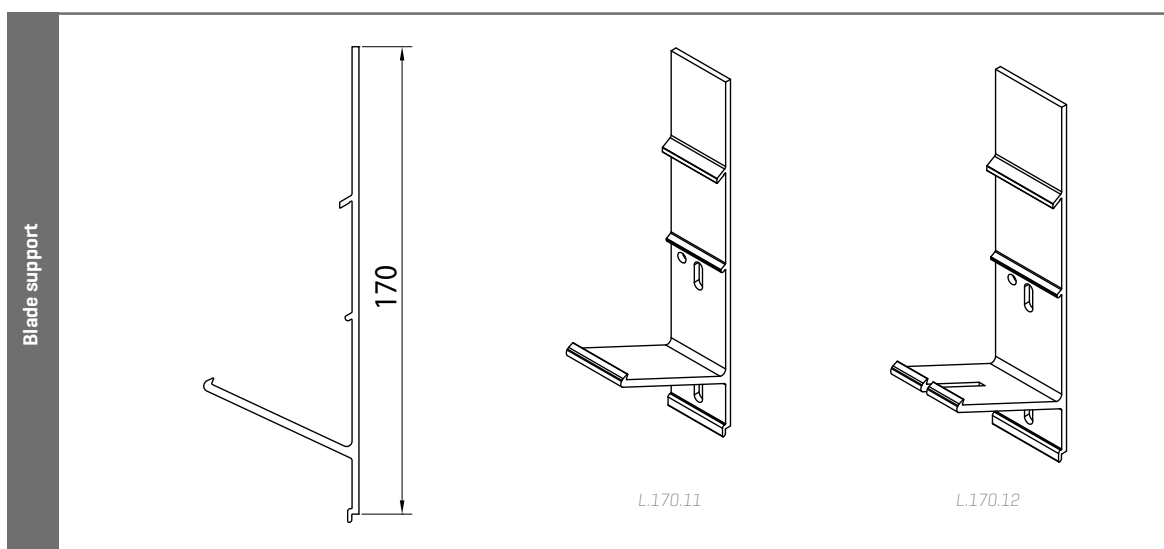
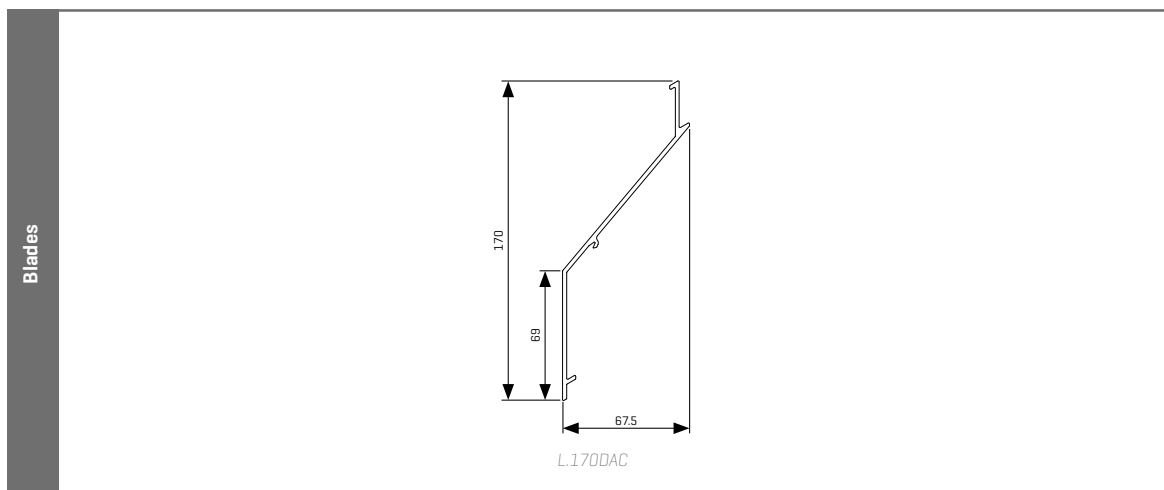

SUNCLIPS® EVO





SUNCLIPS® EVO

Extruded aluminium | aesthetic blades for wall cladding / sun protection

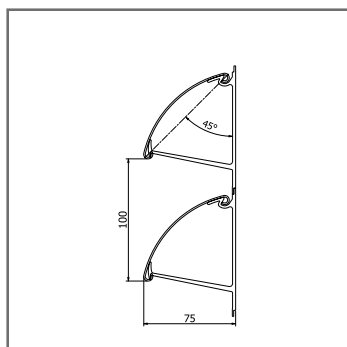

SE.096

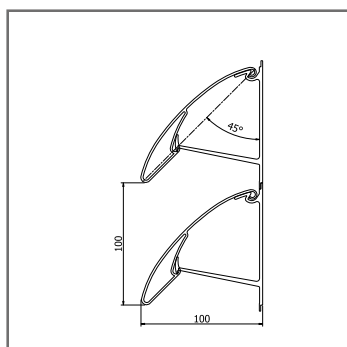

SE.130

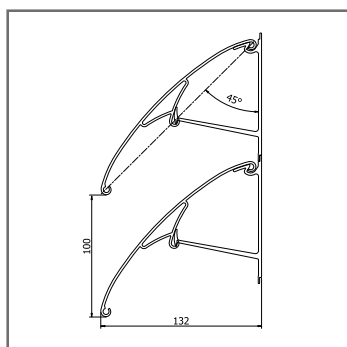

SE.176

Sunclips Evo blades composed of extruded aluminium profiles useable as solar shading, cladding or visual barrier. Sunclips Evo blades are semi-open C-shaped profiles fitted with screw ducts with 96, 130 and 176 mm oversizing.

MATERIALS

Aluminium extrusion, alloy EN AW 6063 T66

FINISH

- Anodised [20 micron]
- Polyester powder coating RAL or Syntha Pulvin colours (60 - 80 μ /40 μ [UK])

MESH

Fixed to rear of the support structure.

DOORS

Single and double doors available with standard Renson® hardware and rotating on pivot [see p. 106]

BLADE SUPPORT

- Single blade support: Type SE.082.11 [width: 28 mm]
- Double blade support for thermal expansion: SE.082.12 [width: 45 mm] [connecting piece for 2 blades]

TECHNICAL DATA

	SE.096	SE.130	SE.176
Pitch	variabel (min. 100mm)		
Depth en Height	70 mm	94,5 mm	127 mm
Physical free area* Evo 96	53%	53%	53%
K-Factor* Evo 96	6,23	6,23	6,23
Max. unsupported span between two mullions**	1200 mm	1800 mm	1800 mm

* Definition see p. 6

** At q_p 800 Pa wind pressure

TECHNICAL DRAWINGS

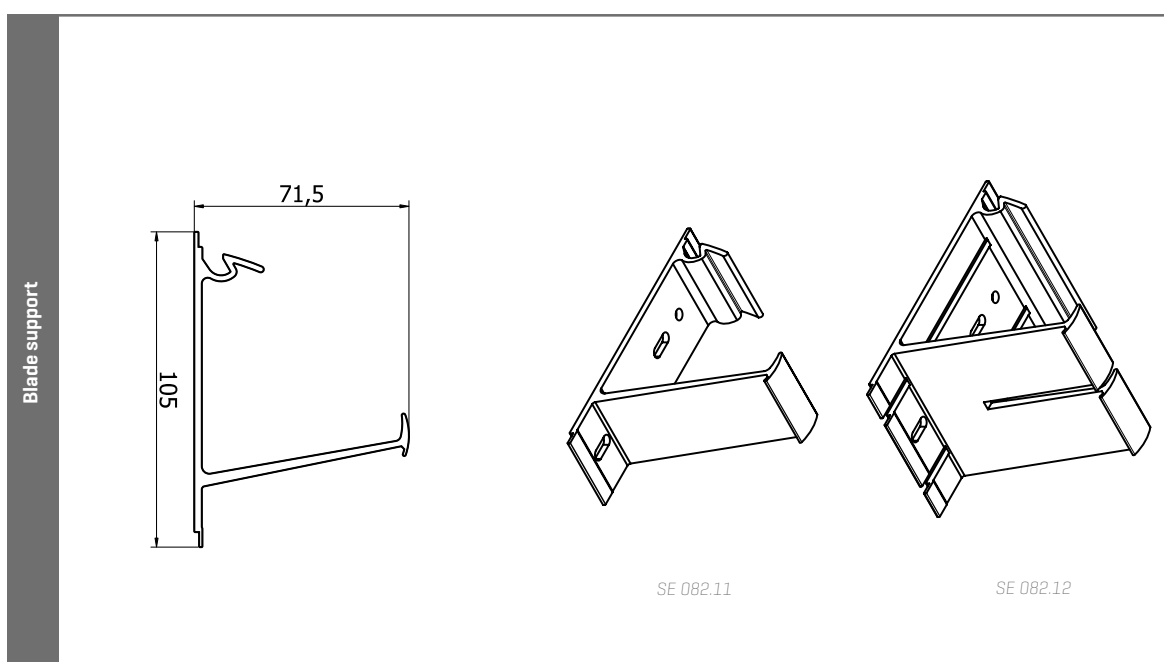
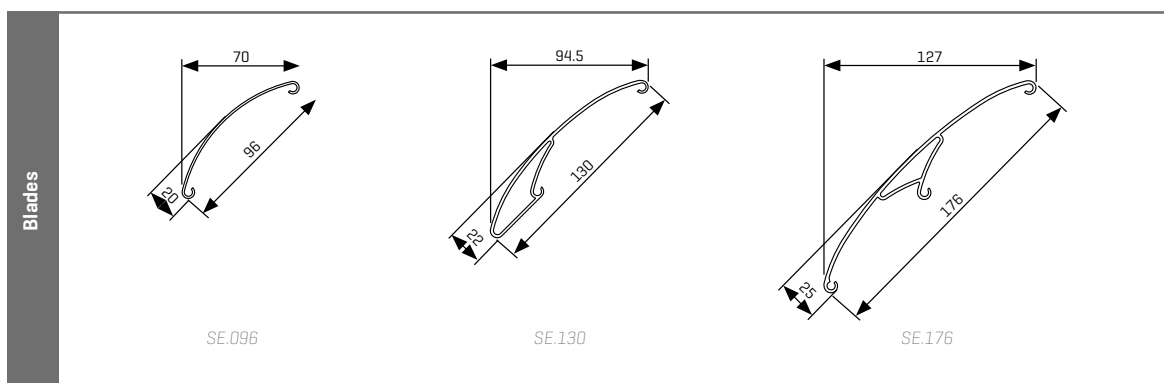



SUPPORTING STRUCTURES





A system consisting of extruded aluminium mullions on which the blade supports and blades are fixed.

The fully homogenous structure is designed according to CEN/TC 250/SC9 Eurocode - 9/ BS8118 for the structural use of aluminium. The fitting of the mullions is determined in accordance with CEN/TC 250/SC1 Eurocode 1/BS, section 3 and good craftsmanship.





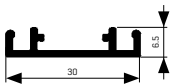
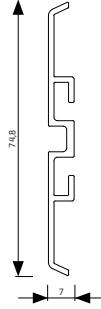
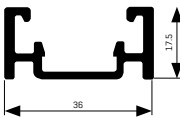
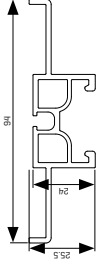
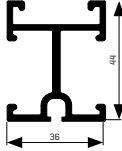
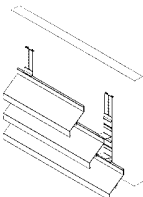
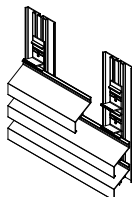
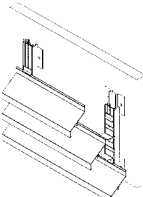
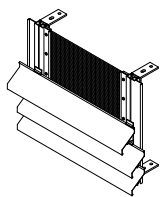
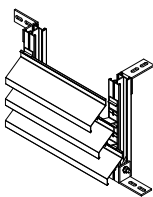

The blades click tight onto the blade supports. The choice of the pitch and other aspects is based on the data described on page 98. The various options of doors, mitred corners and acoustic elements can be selected and integrated in the design.

The complete supporting structure is prepared for the fastening of the blade supports. Fastening can already fully take place at the factory or be partly left for assembly on the site. With the last option one has the flexibility to fasten the last blade supports on site and cut the mullions to size for a perfect installation.

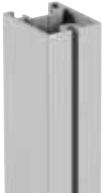
OVERVIEW SUPPORTING STRUCTURES

SUPPORTING STRUCTURES LINIUS						
Mullion	LD.0065	LD.0070	LD.0195	LD.0240	LD.0440	
Application	Extruded aluminium profile for continuous support, directly assembled on an existing wall or steel supporting structure.	Extruded aluminium profile for continuous support, directly assembled on an existing wall or steel supporting structure.	Extruded aluminium profile for limited vertical span, directly assembled on an existing wall or steel supporting structure.	For lateral fixation of insect mesh.	For constructions and sideways fixation.	
Profile depth	6,5 mm	7 mm	17,5 mm	25,5 mm	44 mm	
Profile width	30 mm	74,8 mm	36 mm	94 mm	36 mm	
Moment of inertia	261 mm ⁴	930 mm ⁴	5931 mm ⁴	17402 mm ⁴	83228 mm ⁴	
Section modulus	60 mm ³	211 mm ³	570 mm ³	1120 mm ³	3622 mm ³	
Max. span [Hmax]	± 500 mm	-	± 600 mm	± 1000 mm	± 1500 mm	
						
						
						

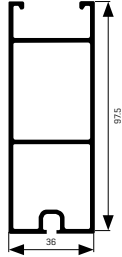
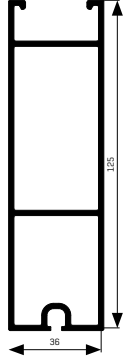
[* Max. span is calculated for a wind pressure of 800Pa and depends on applicable laws and the blade type]

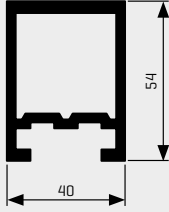
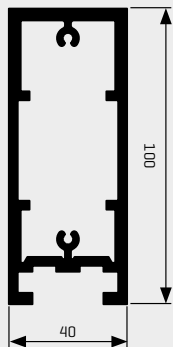
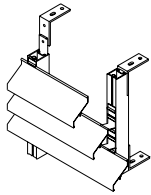
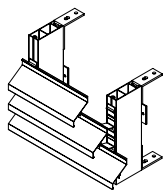
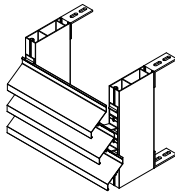
				SUPPORTING STRUCTURES SUNCLIPS		
LD.0460	LD.0995	LD.1250	SD.014	SD.054	SD.100	
For medium vertical span.	For large vertical spans.	For very large spans.	Extruded aluminium profiles, always to be used in combination with adapter profile LD.0108 (depth 14, 54 and 100 mm) as supporting structure for aesthetic application. Also for use in combination with Linius blades as horizontal sun blind.			
44 mm	97,5 mm	125 mm	14,5 mm	54 mm	100 mm	
36 mm	36 mm	36 mm	40 mm	40 mm	40 mm	
83357 mm ⁴	625600 mm ⁴	1219444 mm ⁴	4506 mm ⁴	208600 mm ⁴	1248321 mm ⁴	
3462 mm ³	12100 mm ³	18531 mm ³	495 mm ³	7371 mm ³	24381 mm ³	
± 1500 mm	± 2800 mm	± 3600 mm	± 600 mm	± 2000 mm	± 3600 mm	
						
						
			Adapter profile LD.0108 			

MATERIALS

Aluminium extrusion, alloy EN AW 6063 T66

FINISH

- Anodised [20 micron]
- Polyester powder coating RAL or Syntha Pulvin colours [60 - 80 µ/40 µ (UK)]

SYSTEM DEPTH

- L.033.01 / L.033.08 / L.033HF / L.033CL/L.033IM1
- L.033V
- L.050.00 / L.050.25 / L.050HF / L.050CL / L.050IM1 / L.050IM2
- L.050W
- L.050WS
- L.060HF
- L.060AC
- L.065AL / L.065AL.02
- L.066.01 / L.066S / L.066CL / L.066IM1
- L.066.06
- L.066P
- L.066V
- L.075W
- L.075HF
- L.095.01 / L.095S
- L.120
- L.150DAC / L.170DAC
- L.150ACS / L.170ACS
- L.150ACL / L.170ACL
- SE.096.01
- SE.130.01
- SE.176.01

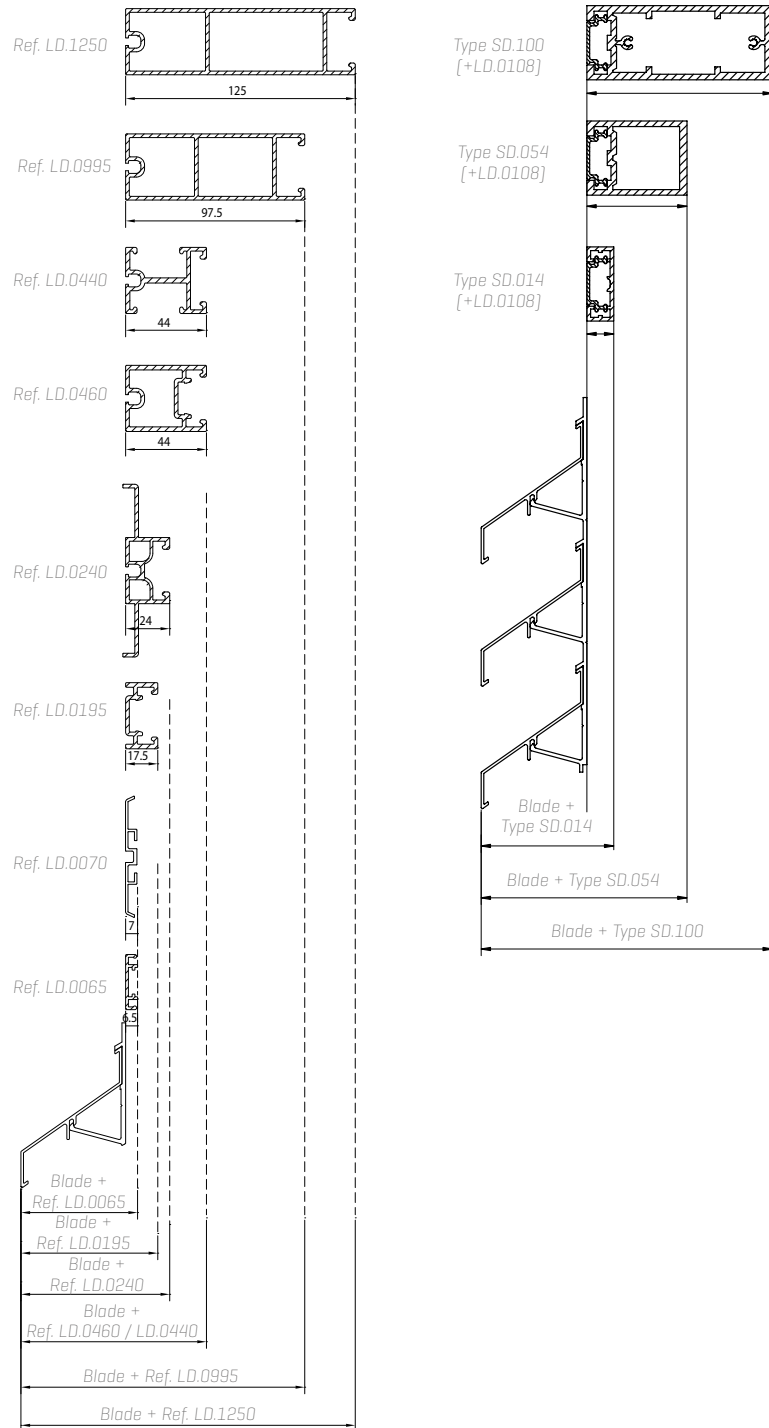

TOTAL DEPTH OF A CONTINUOUS LOUVRE SYSTEM (IN MM)

	LD.0065	LD.0070	LD.0195	LD.0240	LD.0440	LD.0460	LD.0995	LD.1250	SD.014	SD.054	SD.100
L.033.01 / L.033.08 / L.033HF / L.033CL/L.033IM1	29	29,5	40	46,5	66,5	66,5	120	147,5	37	76,5	122,5
L.033V	48,1	48,6	59,1	65,6	85,6	85,6	139,1	166,6	56,1	95,6	141,6
L.050.00 / L.050.25 / L.050HF / L.050CL / L.050IM1 / L.050IM2	49,5	50	60,5	67	87	87	140,5	168	57,5	97	143
L.050W	139	139,5	150	157	177	177	230	258	147	187	233
L.050WS	59	59,5	70	76,5	96,5	96,5	150	177,5	66,5	106,5	152,5
L.060HF	87	87,5	98	104	124	124	178	205	95	134	180
L.060AC	83	83,5	94	100	120	120	174	201	91	130	176
L.065AL / L.065AL.02	58,5	59	69,5	76	96	96	149,5	177	66,5	106	152
L.066.01 / L.066S / L.066CL / L.066IM1	63,5	64	74,5	81	101	101	154,5	182	71,5	111	157
L.066.06	39,5	40	50,5	57	77	77	130,5	158	47,5	87	133
L.066P	61,5	62	72,5	79	99	99	152,5	180	69,5	109	155
L.066V	70	70,5	81	87,5	107,5	107,5	161	188,5	78	117,5	163,5
L.075W	86	86,5	97	103	123	123	177	204	94	133	179
L.075HF	63,5	64	74,5	81	101	101	154,5	182	71,5	111	157
L.095.01 / L.095S	86	86,5	97	103,5	123,5	123,5	177	204,5	94	133,5	179,5
L.120	99	99,5	110	117	137	137	190	218	107	147	193
L.150DAC / L.170DAC	76,5	77	87,5	94	114	114	167,5	195	84,5	124	170
L.150ACS / L.170ACS	176,5	177	187,5	194	214	214	267,5	295	184,5	224	270
L.150ACL / L.170ACL	251,5	252	262,5	269	289	289	342,5	370	259,5	299	345
SE.096.01	81,8	82,3	92,8	99,3	119,3	119,3	172,8	200,3	89,8	126,3	175,3
SE.130.01	106,2	106,7	117,2	123,7	143,7	143,7	197,2	224,7	114,2	153,7	199,7
SE.176.01	138,2	138,7	149,2	157,7	175,7	175,7	229	256,7	146,2	185,7	231,7

FIXING BRACKETS

The Linius mullions are fixed to an existing structure by means of specific brackets. Using brackets type LZ.4206, LZ.4209, LZ.4210 and LZ.4211 of the standard Renson® product range, assembly of the mullions is easy in most situations.

The corners LZ.4203 and LZ.4209 are assembled on the rear of the mullions by means of clamping pieces LZ.4202 or LZ.4211. These parts have a thread or press bolt, which allows them to be fixed at any height to the support structure.

The LZ.4206 bracket slides into the rear of the supporting sections and can move freely in these profiles. A fastening point with this bracket guarantees horizontal stability but allows vertical movement due to thermal expansion. Mounting bracket LZ.4210 is used for wall mounting or ground mounting.

The type of bracket and the amount needed depends on the properties of each type of mullion.



Fixing brackets LZ.4202 and LZ.4211

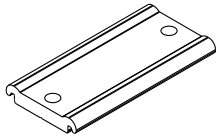
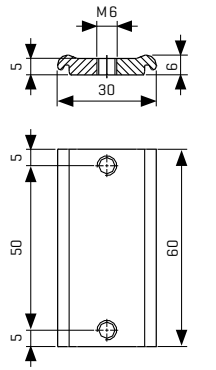

Type LZ.4202

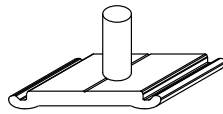
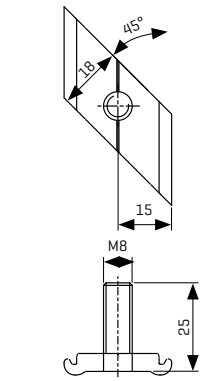

Type LZ.4211

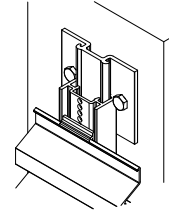
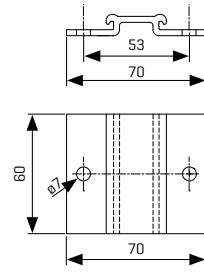

Type LZ.4206

Angle bracket LZ.4214

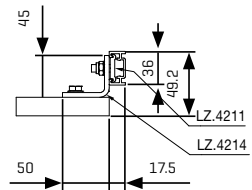
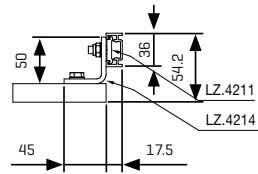
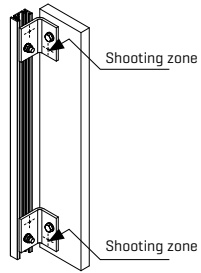
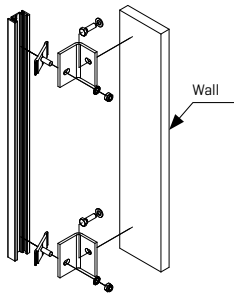

FIXING BRACKETS

U-shape mounting bracket LZ.4210
for supporting structure Linius

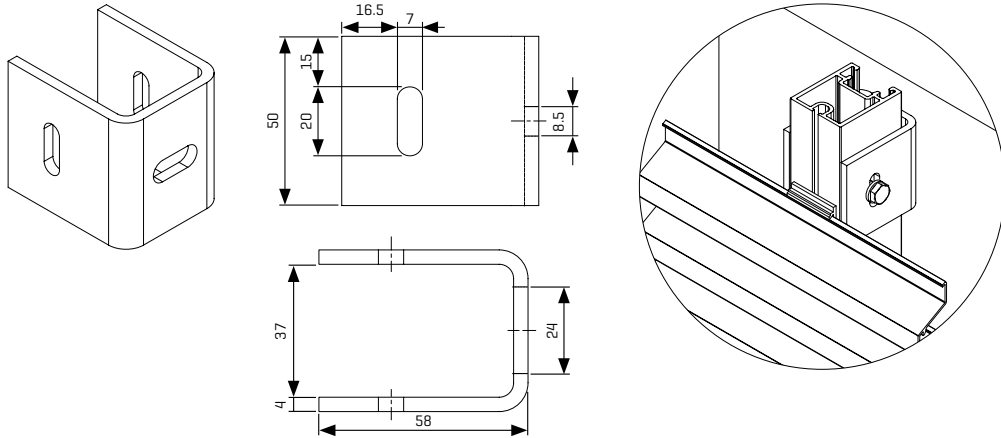

U-shape mounting bracket SD.086.11
for supporting structure Sunclips

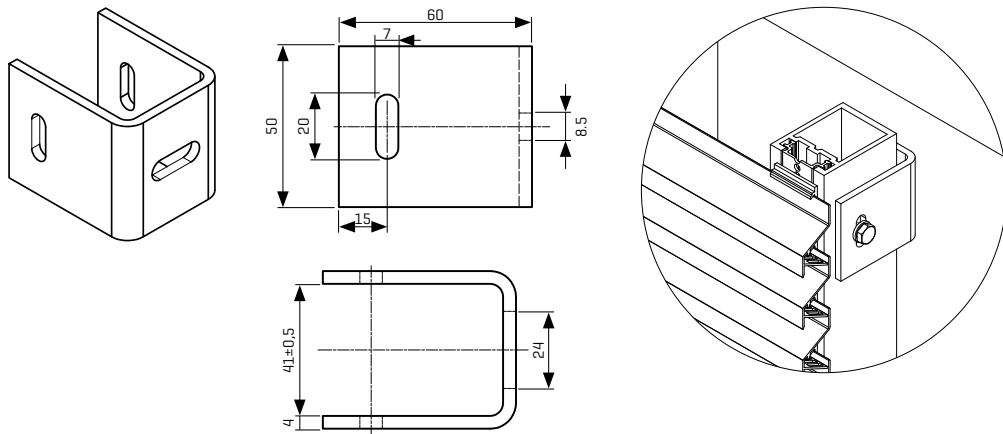

LZ.4215

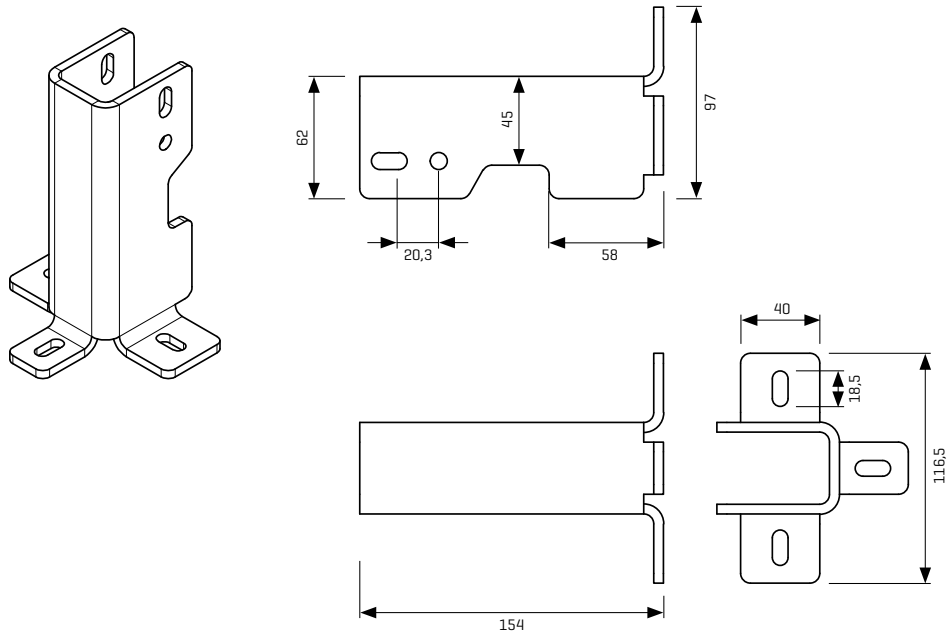

Angle bracket LZ.4203 and LZ.4209

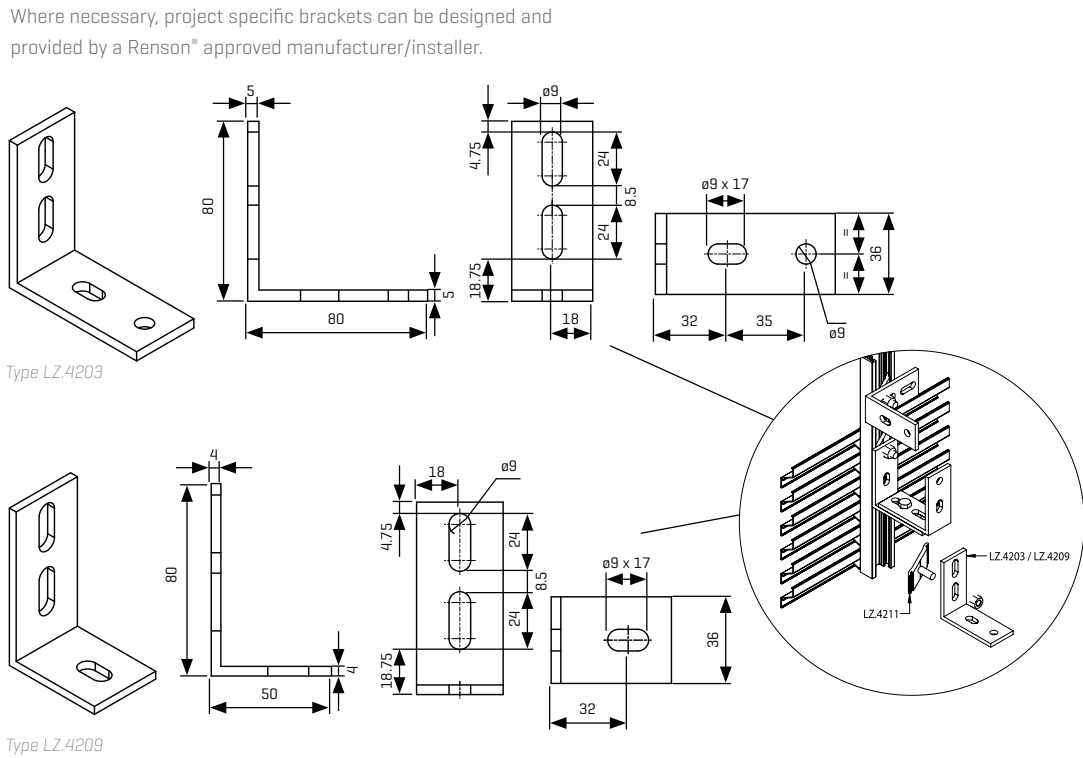

ACCESSORIES





MESH

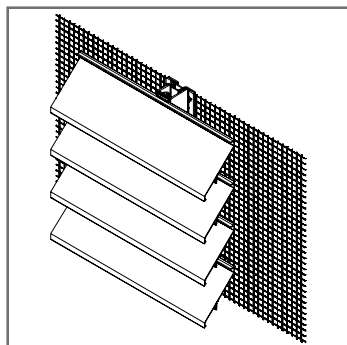

Renson® offers various types of mesh to prevent the entry of insects, birds or vermin behind the continuous louvre system.

1. THE MESH CAN BE RIVETED TO THE REAR OF THE CLS BY MEANS OF A FLAT PROFILE.

Various types mesh of stainless steel 304L of different sizes are available on rolls:

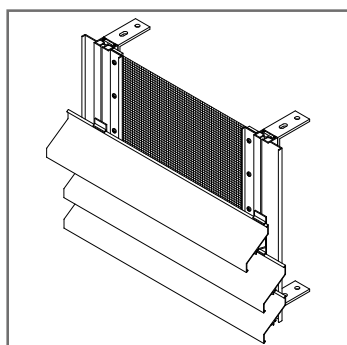
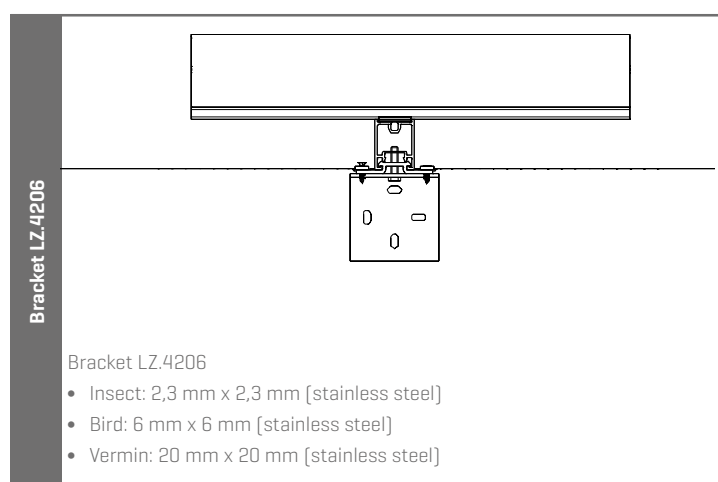

2. SUPPORT LD.0240 FOR LATERAL FIXATION OF MESH

3. THE MESH CAN BE CLIPPED BETWEEN TWO BLADES. THIS IS POSSIBLE WITH BLADE TYPE L.095

For blade type L.095.01, there are 2 types of meshes:

- Dense sheet (BOP) L.095.31
- Bird mesh L.095.33
 - K-Factor = 15,38
 - Physical free area = 42%

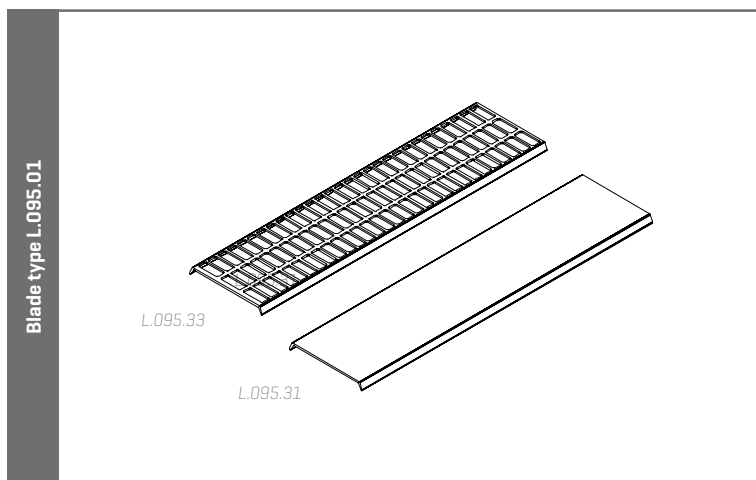

4. LOCKING TOOLS

Due to thermal dilatation, aluminium blades might start moving in the course of time. In order to avoid this, the blades can be locked by means of a locking tool. This tool is available for blades type: L.033.01, L.033CL, L.050HF, L.050CL, L.050W, L.060HF, L.066.01, L.066.06, L.066CL, L.075W, L.075HF, L.095 and L.120.

5. UNCLIPPING TOOL

If blades are to be removed, the blade removing tool can be used. This blade removing tool is available for L.050.00, L.050HF, L.060HF, L.066.01, L.075.01, L.075HF and L.095.



SILLS

A sill (type LZ.4140) can be fitted in the CL S to drain rain water off.

Fastener for a sill type LZ.4201

Instead of a sill, a frame can be used for the L.075 system (see page 104).

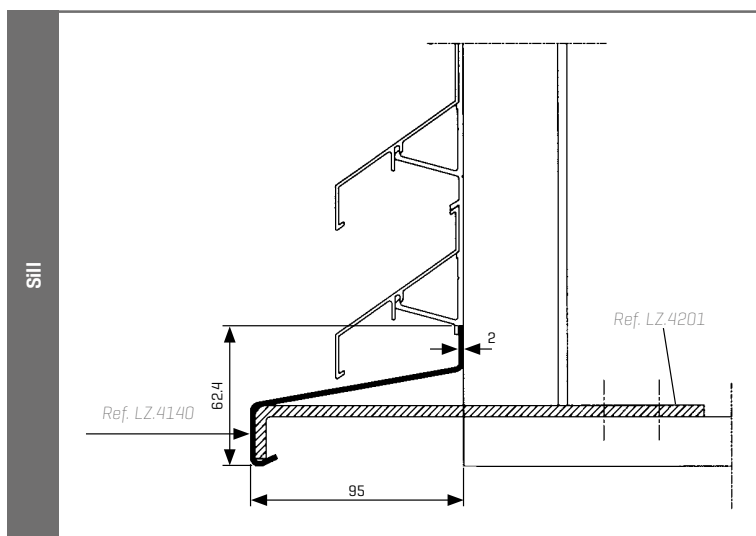

ALUMINIUM FRAMES

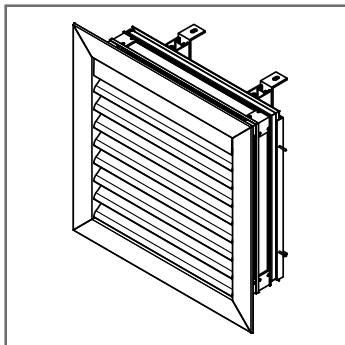

L.050W

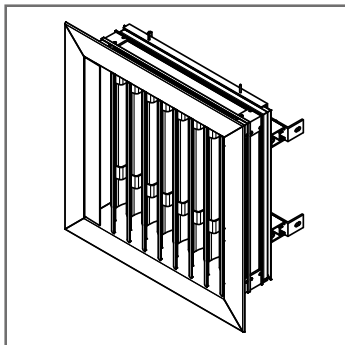

L.050WV

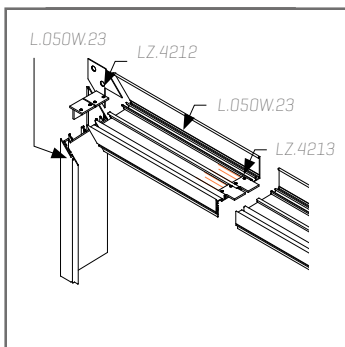

L.050W/ L.050WV

The high performant system L.050W can be provided with an optional frame profile L.050W.21 which will result in an ideal water drainage. This frame profile will be installed both horizontally and vertically around the wall opening and is used in combination with mullion profile LD.0460. These mullion profiles LD.0460, with pre-assembled clipses L.050W.11, are to be installed onto structural mullions (type Renson® or a structural sub-structure) and provided with stainless steel mesh. In this way incoming water is drained back to the outside.

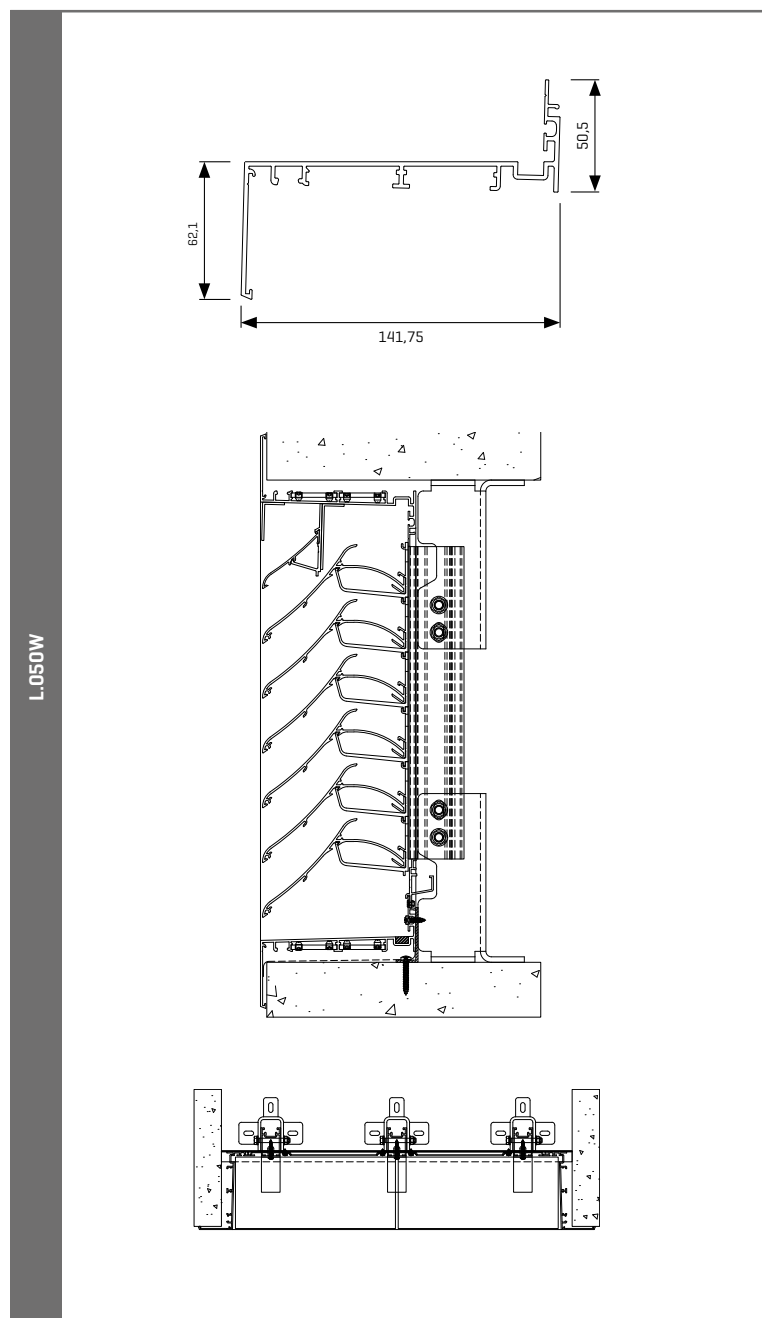

L.075W

The louvre system type 75 has been designed with the option of being provided with a frame with or without flange.

The design with flange gives the aesthetically attractive appearance of a continuous blade surface. A sealing rubber can be used to give the louvre a perfect finish so use of silicone putty is unnecessary.

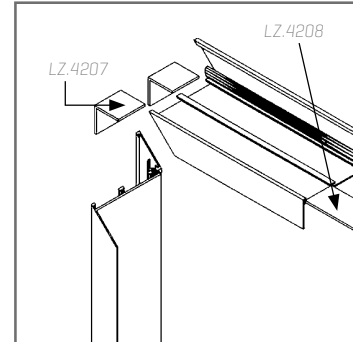
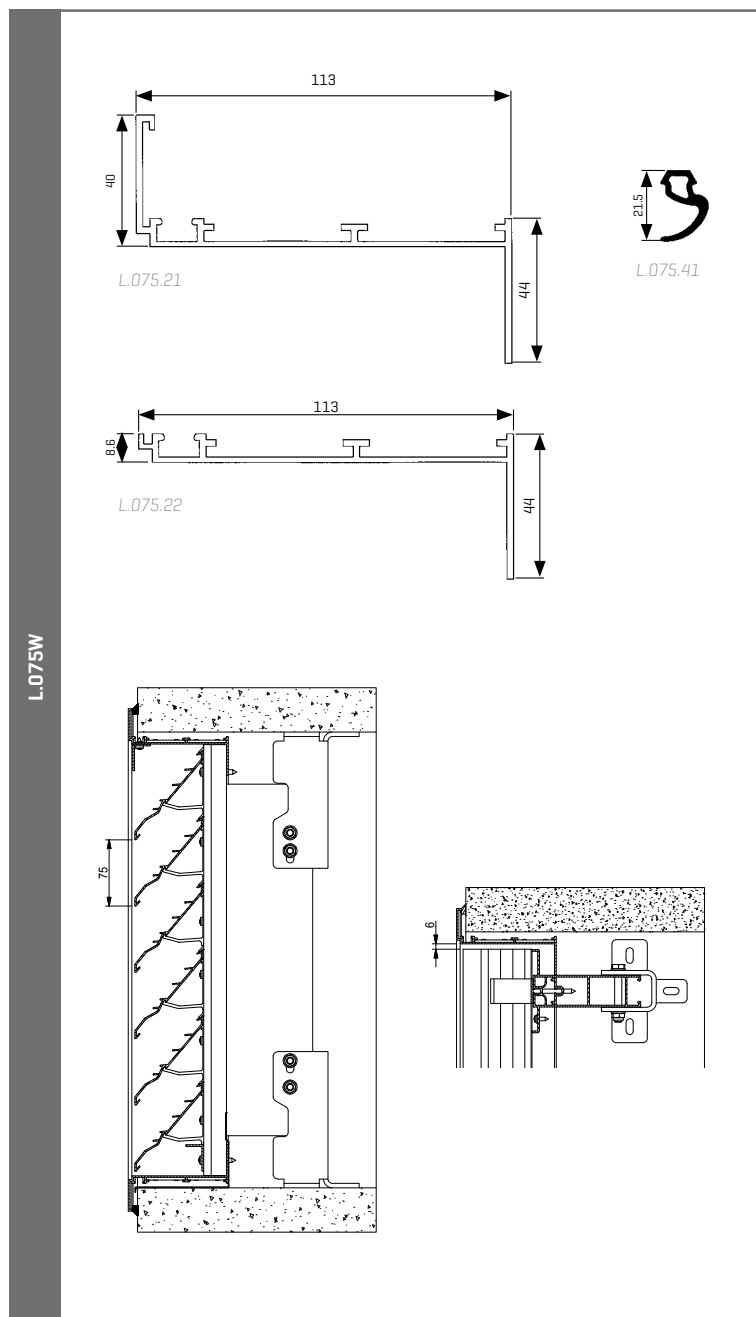

LZ.4207: Corner trim connector
LZ.4208: Intermediate trim connector

DOORS



Renson® offers single or double doors in custom made sizes, opening inwards or outwards. In some cases, access behind the continuous louvre system is required, for example to maintain and service [hidden] industrial appliances. The doors are fitted with locks, pivots, handles and restraining chain upon specification.

DIFFERENCE BETWEEN OVERALL SIZE [O] AND CLEAR DOOR OPENING [C]

Blade type:	L.033 / L.033.08		L.039V		L.050 / L.050HF		L.060AC / L.060HF		L.065AL		L.066 / L.075HF	
O - C (mm)	single	double	single	double	single	double	single	double	single	double	single	double
Opening outwards	259,5	399	259,5	399	259,5	399	279,5	439	259,5	399	259,5	399
Opening inwards	218	-	237	-	238,5	-	275,5	-	246	-	252,5	-

Blade type:	L.066P		L.066V		L.095		L.120		L.150ACS	
O - C (mm)	single	double	single	double	single	double	single	double	single	double
Opening outwards	259,5	399	259,5	399	279,5	439	309,5	499	539,5	959
Opening inwards	252,5	-	246	-	275,5	-	288	-	365	-

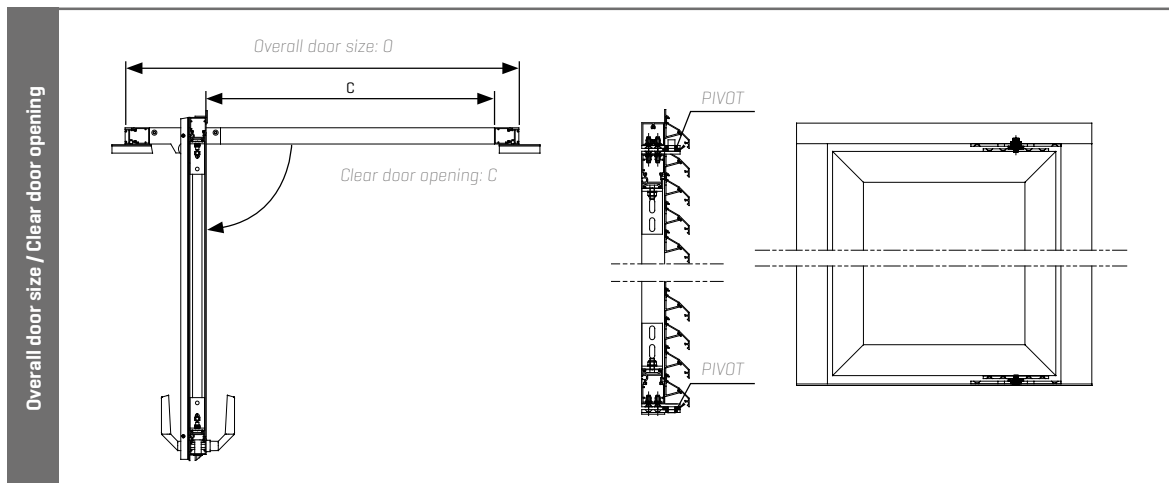

Please note that the actual opening [C] is smaller than the total door size [O] due to the pivoting mechanism. The position of the pivot system will in turn depend on the total load of the louvre door. Renson® can assist you in determining the correct sizes.

HANDLES AND LOCKS

One can choose between none, a single or a double door handle. If you choose not to fit a door handle you can open and close the door with the key to the lock. The handle can be a fixed door knob or a standard handle. It is important to specify the handle type.

The Litto cylinder is the only approved option. Other proposals can be considered if full technical data is provided to Renson®. Other types are available on request.

Accessories such as door dampers, storm chain,... are available on request.

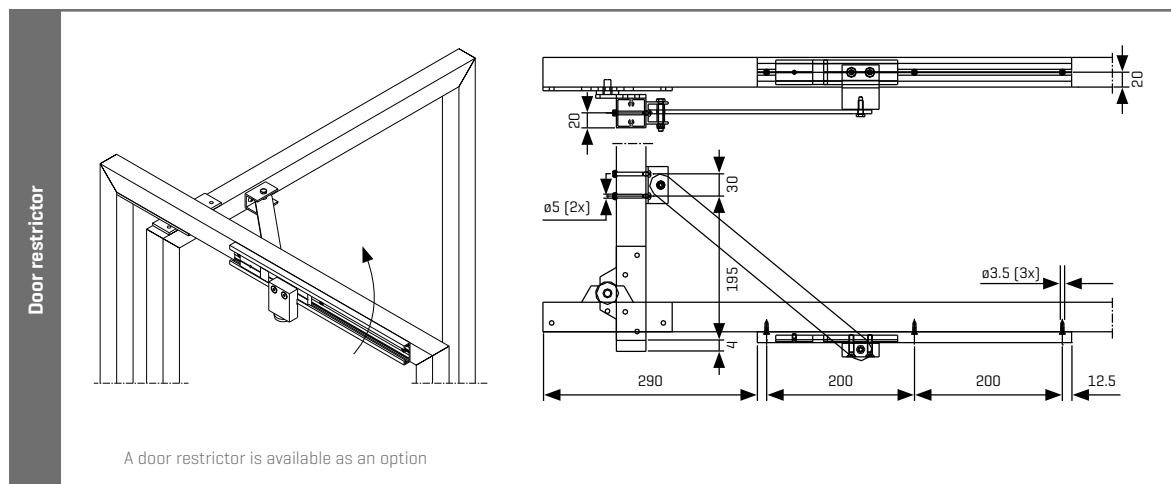
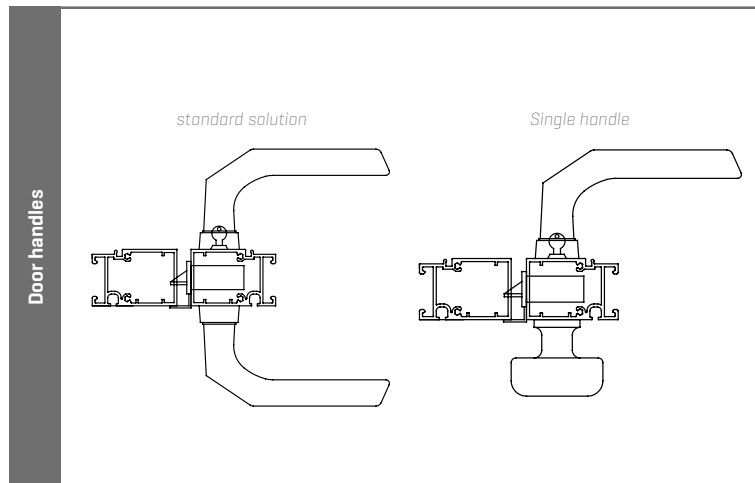

SPECIALITIES

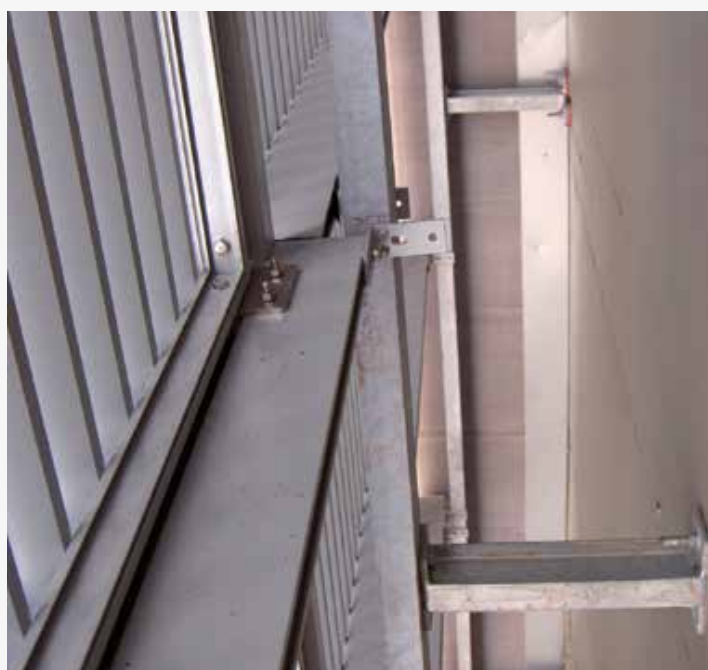



LINIUS® - UNITIZED SYSTEM



Innovative products are always challenging in terms of design, technique, flexibility and quality! To save valuable time in the assembly process on site, Renson® developed the Linius unitized system. The advantage of this system is that it allows an entire louvre system to be divided into modules, which arrive on site in pre-assembled condition. Upon installation of the mullions on site, successive cassettes can be easily and quickly installed using a clasp system.

BENEFITS

- Delivered as pre-assembled cassettes, hence:
 - Quick installation, using clasped blades and simple clasp system
 - Simple installation and alignment
 - Easy assembly in hard-to-reach areas, e.g. high installations, only accessible from the interior ...
- Elements with invisible, encompassing frames
- Removable cassettes, e.g. machine areas
- Reclining elements possible
- Available with enfolded stainless steel mesh
- Elements for mitred corners possible
- Aesthetic appearance, solid and stable system

PROPERTIES

- Max. dimensions: 4m² per element – 9 to 16kg/m²
- Cassette layout optional according to grid
- All Linius® range blades are suitable
- Assembly using lever for smaller cassettes
OR using hoisting eye for larger cassettes and for high installations (crane)
- Technical documentation available

MATERIALS

Aluminium extrusion, alloy EN AW 6063 T66.

FINISH

- Anodised (20 micron)
- Polyester powder coating RAL or Syntha Pulvin colours (60 - 80 µ/40 µ [UK])

MESH

Enfolded assembly of stainless steel mesh to the back of the cassettes



Lever



Lifting eye

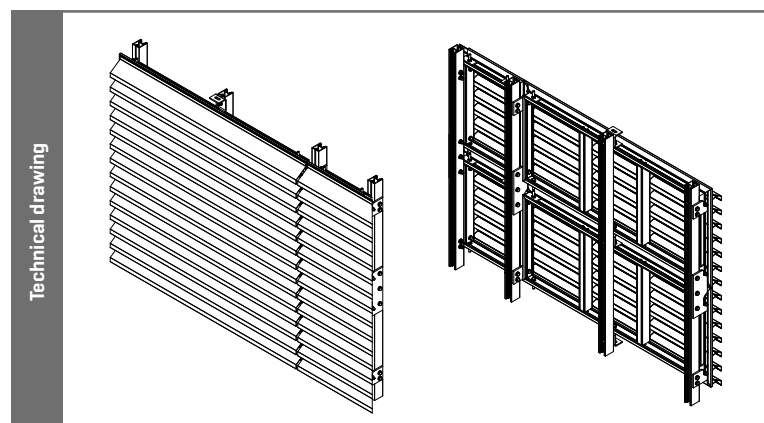

Technical drawing

CURVED BLADES

Today's designs often call for expressive forms giving a building a specific look. Renson® has developed a curved assembly system that allows the architect's creativity to be transformed into reality.

Blade types L.033.01, L.033HF, L.050.00 and L.050HF can be delivered with an minimal outer radius of 800 mm.

In addition, blade types L.033.01 and L.050.00 can also be curved with a minimal inner radius of 800 mm.

Plans for such a curved design must be submitted to the technical department at Renson® for approval before the start of the construction process.

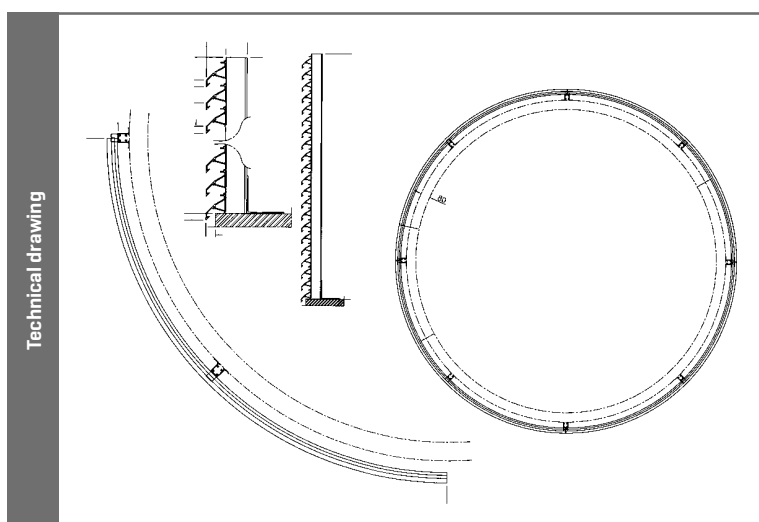

STAND ALONE SUPPORT STRUCTURES

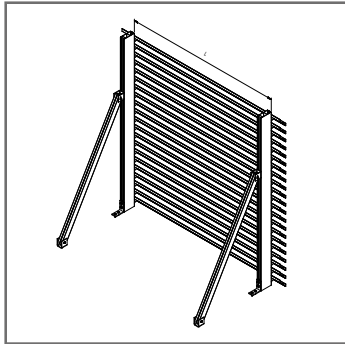

This system is used for freestanding louvre systems of limited sizes and/or wind loads where an additional primary steel structure is rendered unnecessary by a self-supporting aluminium structure.

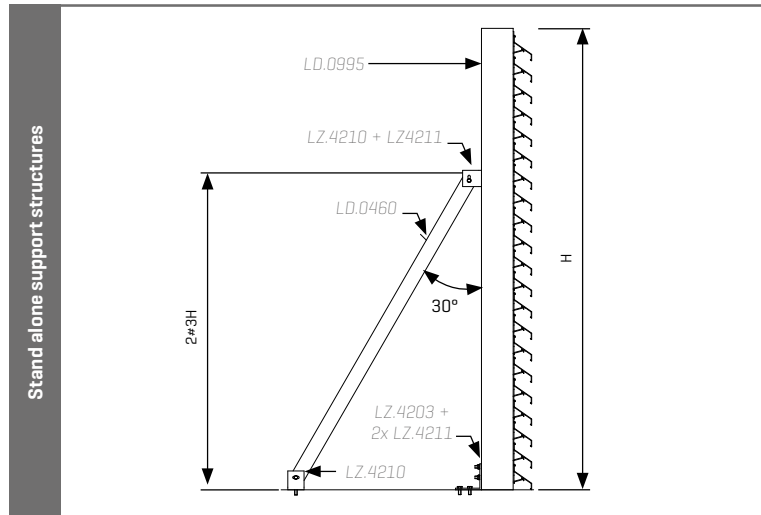

ACOUSTIC APPLICATIONS

Noise nuisance is an environmental pollutant. We at Renson® are fully aware of this. As a solution, Renson® offers an acoustic louvre that reduces noise pollution and complies with existing regulations.

This acoustic louvre system allows air passage while reducing noise passage. The Renson® technical department is at your disposal to advise and discuss a suitable acoustic construction.

In order to determine the ideal solution, the following factors are important:

- the desired dB noise level
- the noise level of the noise source
- the distance and location of the noise
- the required flow rate

The acoustic continuous louvre system consists of a support structure, acoustic blades and blade supports.

The acoustic blade is filled with sound absorbing and non-combustible mineral wool.

See pages 42, 72 and 78.

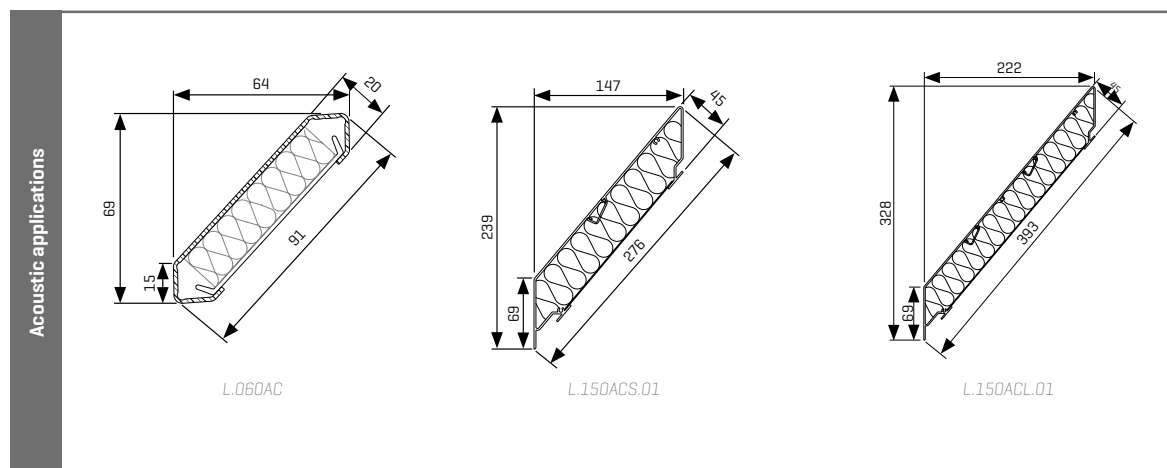

MITRED CORNERS

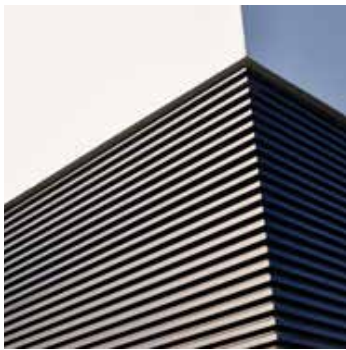

Where a corner is formed, the blades are cut to the correct angle so they fit perfectly and ensure an attractive aesthetic finish.

POSSIBLE SOLUTIONS TO FIT CORNERS

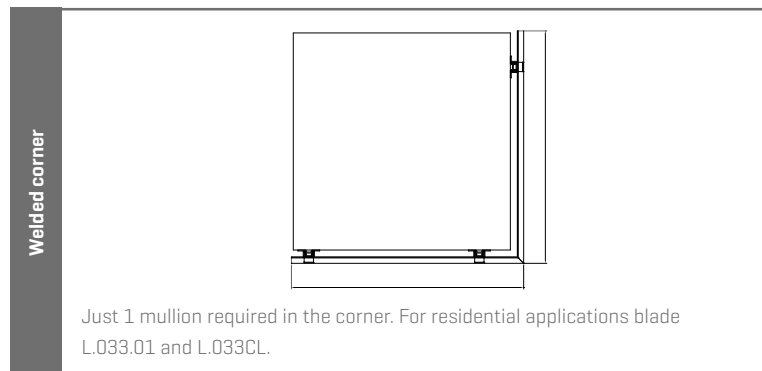
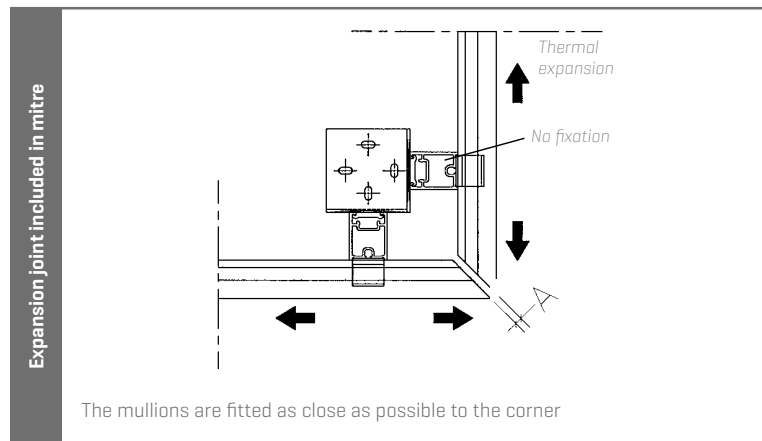
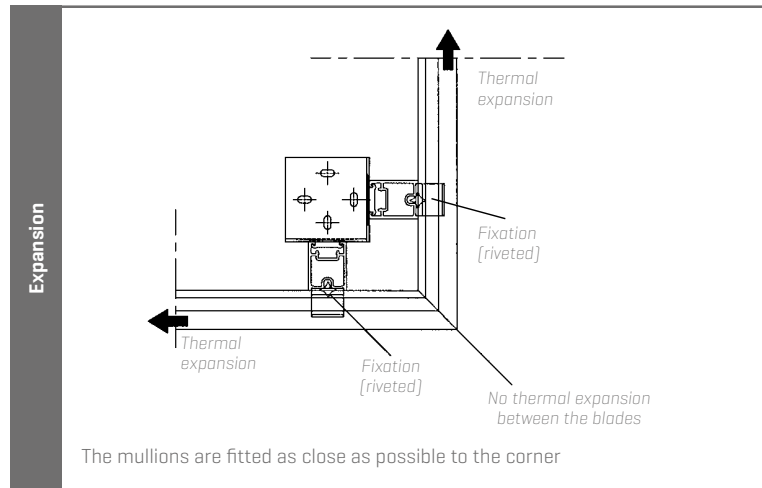

SPECIAL SHAPES

Renson® long ago moved on from the limits of a simple square design, and has continuously conceived solutions for specific applications. These are applications mainly intended to create a certain aesthetic added value, but also applications where functional requirements must be combined with a contemporary design.



BLOCK BLADES L.033 AND L.050



This type of blade offers fast and easy assembly and better vandalism-resistance than the standard aluminium CL S. The blades can only be used for riveting or screw-fixing to an existing full back structure (wall, metal sheeting, ...).

The extruded profiles are only available in types L.033 or L.050.

They consist of 3 to 4 blades extruded together. The profiles are available as punched [L.033.07 / L.050.07] or unpunched [L.033.05 / L.050.05] versions. The block blades can be used in conjunction with the standard blades.

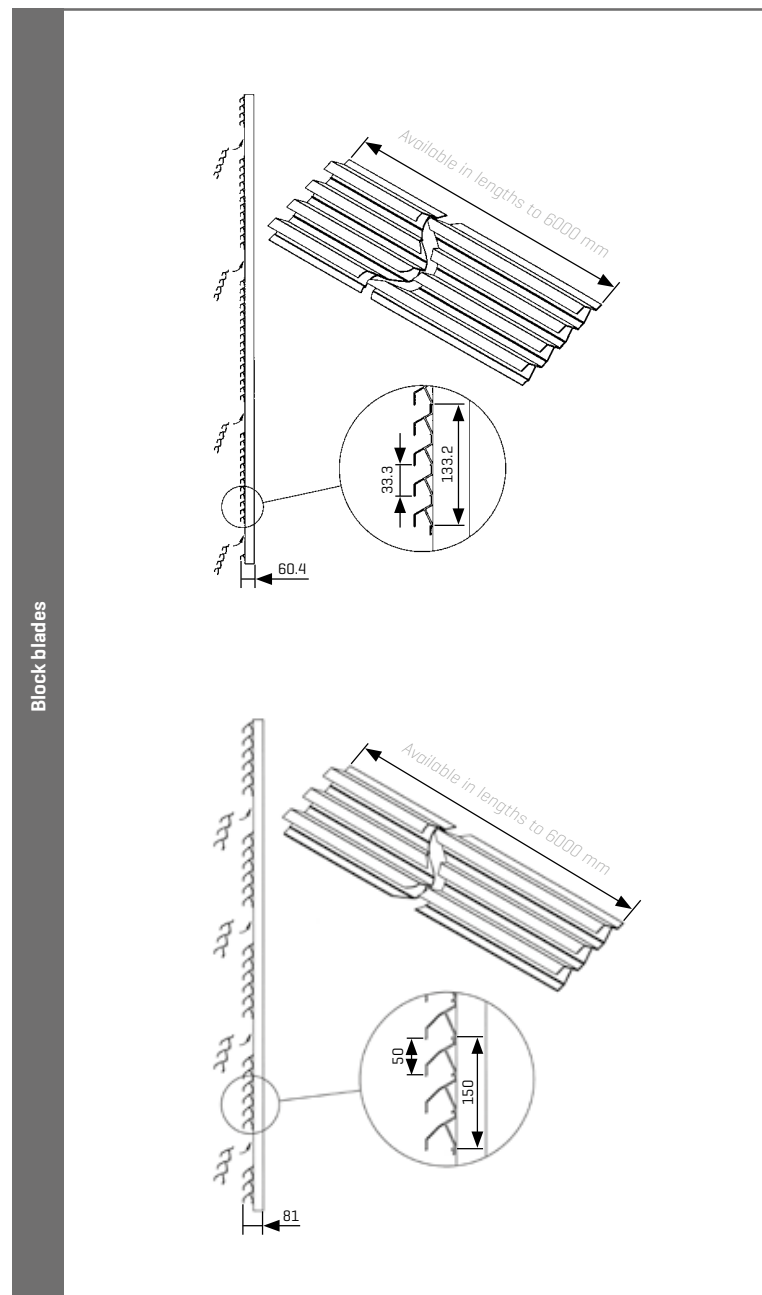

TURRETS

A turret is placed on the rooftop of buildings to conceal industrial appliances. [chimney stacks,....]

Renson® takes care of complete construction including the top plate and sill.

